

## Mechanical Level Command

### INSTALLATION INSTRUCTIONS

Congratulations on your purchase of a new Level Command kit. This kit will provide automatic height control and leveling of your vehicle from front-to-back or from side-to-side.

Please take a few minutes to read through the instructions, identify the components, and learn how to properly install your Level Command kit. Be sure to take all applicable safety precautions during the installation of this kit.

### NOTE:

*Prior to the installation of this kit, you must have installed the air helper spring kit designated for your vehicle. The air compressor accessory kit must also have been installed. See your Ride-Rite dealer for more information.*

### NOTE OF CONNECTION THE AIR LINE TUBING:

#### COMPRESSION FITTING

To connect the tubing to the fitting, first remove the nut and ferrule from the fitting. Slide the nut over the tubing, followed by the ferrule. If the fitting does not have a built-in tube support, insert one from your kit into the end of the tubing. Push the tubing as far as possible into the fitting and tighten the nut on the fitting. Fittings with brass ferrules should be finger-tight plus 3-1/2 turns. Fittings with Nylon ferrules should be finger-tight plus 1-1/2 turns.

#### PUSH-TO-CONNECT FITTING

Your helper springs have push-to-connect fittings. Cut the air line tubing as square as possible. To connect the air line tubing to the fitting, push the tubing into the fitting as far as possible, see Figure "C". If for any reason the tubing must be removed, first release the air pressure from the air system, then push the collar toward the body of the fitting and the tubing can be removed. To reassemble, make sure the tubing is cut square and push the tubing back into the fitting.

### PARTS LIST

HEIGHT CONTROL VALVE	9257	2	LINKAGE PACK 9028	2
AXLE BRACKET	5001	2	LINK SET	2
VALVE MOUNTING BRACKET	5004	2	#10 BOLT	2
18' TUBING	9414	2	#10 WASHER	2
TEE FITTING	3025	2	#10 NUT	2
HOSE CLAMP		2	1/4" X 1-1/4" BOLT	4
3/8"-16 FLANGE LOCK NUT		4	1/4" WASHER	4
3/8"-16 X 3/4" HEX BOLT		4	1/4" NUT	4
NYLON TIE-WRAP		6		

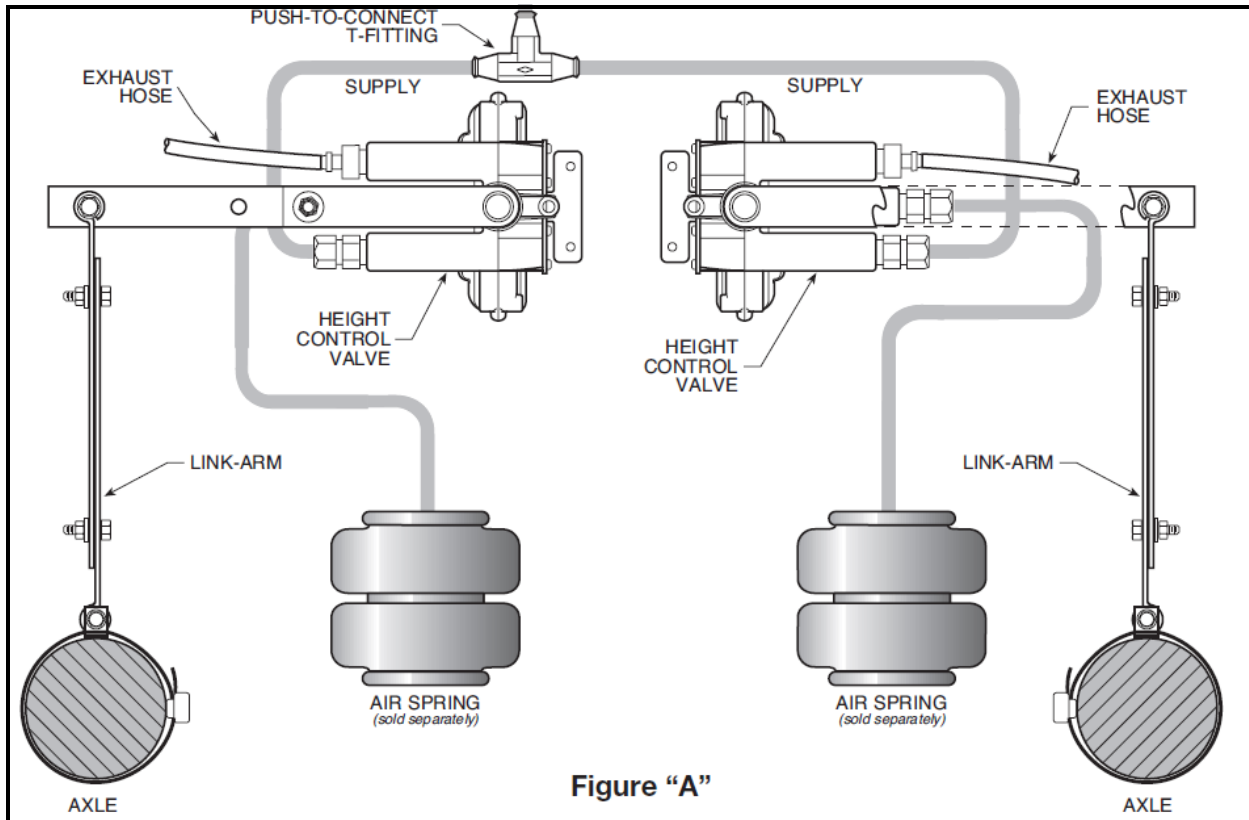

Figure "A"

**STEP 1—PREPARE THE AIR SYTEM**

The air tank and compressor kit should have been previously installed on the vehicle. Ensure that the air tank contains no air pressure. Disconnect the compressor from the power source and then remove the valve core from the external inflation valve or use a tire gage release air pressure from the system. **This installation assumes that there is no load in the vehicle.**

**STEP 2—SELECT A LOCATION FOR THE HEIGHT CONTROL VALVE**

Review **Figure "A"** to become familiar with the installation of the height control valve. The height control valve should be mounted on the frame rail or other convenient location. The height control valve must be in a location that will allow the link-arm to reach the axle housing and be attached without any interference. The valve-arm of the height control valve must have enough clearance to operate freely and the link-arm should be oriented vertically.

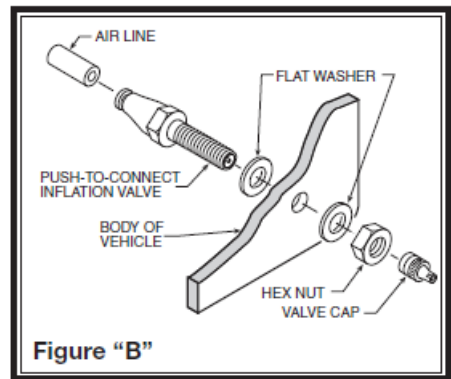

Figure "B"

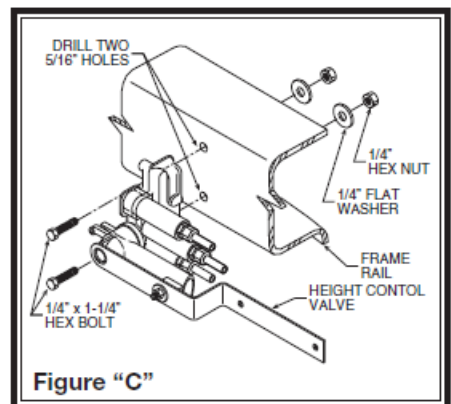
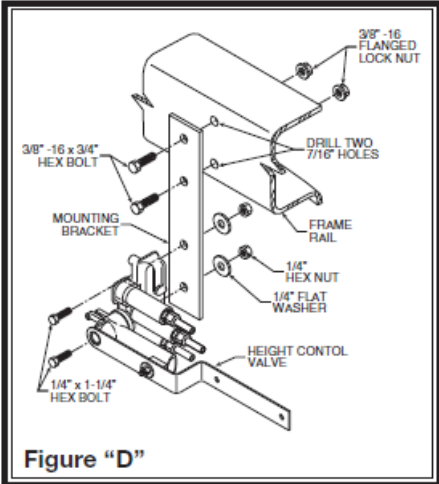
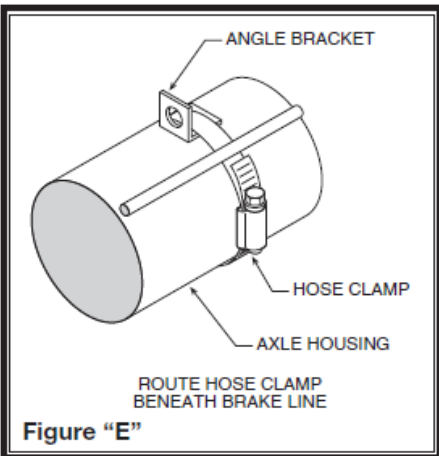

Figure "C"



### STEP 3— MOUNT THE HEIGHT CONTROL VALVE

Mount a height control valve in a location where it may be attached to the frame so that the arm extends over the axle. The valve must be in a location where the link-arm can reach from the valve arm to the axle housing. The height control valve can be attached directly to the frame rail above the axle or on a bracket attached to the frame rail. To attach the height control valve directly to the frame, use the mounting holes on the valve as a template to mark and drill to 5/16" holes. Use the 1/4" x 1-1/4" hex bolts, 1/4" washers and 1/4 hex nuts to secure the valve to the frame, see **Figure "C"**.



The height control valve can be attached to a bracket secured to the frame rail if the link-arm cannot span the distance between the valve arm and the axle housing, **see Figure "D"**. Secure the mounting plate to the height control valve using the 1/4" x 1-1/4" hex bolts, 1/4" hex nuts and 1/4" washers. Using the bracket as a template, mark and drill two 7/16" holes in the frame rail. Attach the bracket to the frame with the provided 3/8"-16 x 3/4" hex bolts and 3/8"-16 flanged lock nuts.

### STEP 4—MOUNT THE ANGLE BRACKET

Place the angle bracket on the axle directly beneath the valve arm. This bracket does not have to be on top of the axle. Find a location on the axle free from obstructions. Place the hose clamp around the axle and the angle bracket and tighten the clamp. Ensure that the hose clamp does not clamp over the brake line, as to avoid damage to the line, **see Figure "E"**.

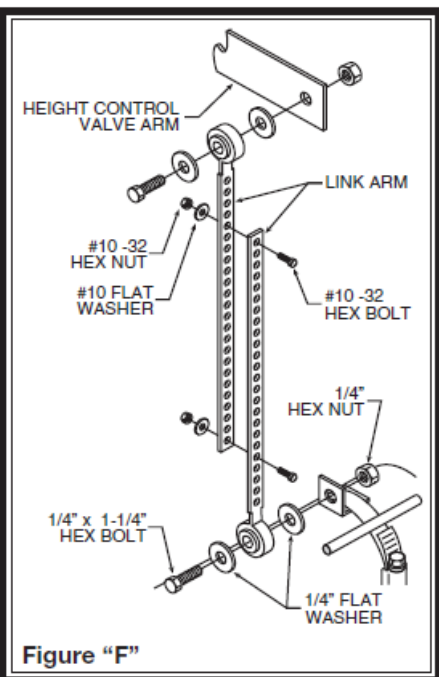

### STEP 5—ATTACHE THE LINK-ARM

Measure the distance from the angle bracket on the axle to the mounting hole on the arm of the height control valve. Ensure that the arm on the height control valve is aligned horizontally. Fasten the individual link-arms together so the ten span the measured distance with the provided #10 hex bolts, #10 hex nuts and #10 washers, **see Figure "F"**. If the link-arms are too long, they can be cut down to allow them to be fastened together.

Fasten the link-arm to the height control valve with a 1/4" x 1-1/4" hex bolt, 1/4" nuts and 1/4 washers, **see Figure "F"**. Follow the same procedure to attach the link-arm to the angle bracket on the axle. The link arm should be installed so that it is aligned as close to vertical as possible.

## **STEP 6—INSTALL THE OTHER SIDE ASSEMBLY**

Follow steps 2 –5 for the other side of the vehicle. Reverse any orientations when assembly and installing the other side.

## **STEP 7—ROUTE THE AIR LINE TUBING**

Check to make sure that there is no air pressure in the air system see **Step 1**. Cut a length of air line tubing that will reach from the air tank to the height control valves. Cut the tubing as square as possible. Insert one end of the air line tubing into the fitting on the air tank. Route the tubing to avoid sharp edges and heat from the exhaust system. Secure the tubing to the vehicle with the Nylon ties provided. Install a T-fitting on the end of the air line. Push the tubing into the fitting as far as possible. Rout a length of air line tubing from the T-fitting to each height control valve. Insert the tubing from the T-fitting into the bottom port on the height control valve, **see Figure "A"**.

If your vehicle has existing air helper springs, release any air pressure from the air springs by removing the valve core from the inflation valve or by using a tire gage to release air. Remove the tubing from the inflation valves. Cut the air line tubing so that it will reach from the air helper spring to the height control valve. Route the air line tubing to avoid sharp edges and heat from the exhaust system. Secure the tubing to the vehicle with the provided Nylon ties. Do not fold or kink the tubing, as it may buckle. Insert the end of the air line from the air spring into the middle port on the height control valve, **see Figure "A"**.

If you are installing air helper spring on your vehicle with the Level Command kit, do not install the air line as stated in the Air Helper Spring instruction manual. Install the air line tubing into the fitting on the air spring, and then route the air line tubing to the T-fitting installed earlier in this step. The installation of the manual inflation valves will not be necessary, as stated in the air helper spring instruction manual.

Install the exhaust fitting and the air line tubing into the to port on the height control valve, **see Figure "A"**. The tubing should be approximately 6" in length. The tubing will allow the air spring to exhaust air when the load is removed from the vehicle.

## **TEST THE SYSTEM**

Re-attach the power source to the compressor. Turn on the vehicle's ignition. The compressor will run for a short period of time to build pressure in the air tank and air springs. The pressure switch will automatically turn the compressor off once the system reaches 120 psi. Check the fittings for leaks with an applied solution of soap and water. If a leak is detected at a tubing connection, check to make sure that the tube is cut as square as possible and is pushed completely into the fitting. The tubing can easily be removed from the fitting by first releasing the air pressure from the system, then by pushing the collar towards the body of the fitting and then pulling out the tube. If a leak is detected where the brass fitting screws into the spring, first release the air pressure, then remove the tubing, followed by screwing the brass fitting into the air spring one additional turn or until the leak stops. Reinstall the tubing and re-inflate the air springs and check for leaks as noted above.

This now completes the installation. When the vehicle is loaded, the Level Command kit will detect the reduction in ride height. The air tank and compressor will inflate your air helper springs until the proper ride height is achieved. When the load is removed, the air springs will automatically be inflated to achieve normal ride height. If your vehicle does not achieve the desired ride height, the length of the link-arms may be increased or decreased.

Note that after a load has been placed on or removed from the vehicle there will be a delay of a few seconds before the Level Command kit responds to the change in ride height.



# Do Not Return This Product to the Dealer or Distributor

## If you are

- missing parts,
- experiencing installation problems, or
- have technical concerns regarding this product,

you may contact a Firestone Technical Service Representative at [rrtech@fsip.com](mailto:rrtech@fsip.com) or at 800-888-0650 (option 1, and then option 2). Representatives are available from 7:30 a.m. – 4:30 p.m. Eastern on Monday – Friday, excluding holidays. If you are located outside of the United States, you should first contact your distributor or dealer directly with any issues.

When contacting Technical Service, please have the kit or part # ready, along with the make, model, and year of the vehicle. You may also need to provide details, such as 2WD/4WD or if the vehicle has been lifted or lowered from stock height.

If you have a warranty concern, please include in your email a detailed description of the situation, a photo(s) of the issue, and your contact information, including ship-to address.

**WARRANTY COVERAGE\***— The Ride-Rite™ kits, components, and accessories are warranted against defects in workmanship and materials. This warranty does not cover service or labor charges, neglect...to the product.

### **PERIOD OF COVERAGE:**

- |                                             |                                                                                  |
|---------------------------------------------|----------------------------------------------------------------------------------|
| • Ride-Rite air springs – Lifetime Limited  | • Work-Rite load assists – 2 Years Limited                                       |
| • Sport-Rite air springs – Lifetime Limited | • Air-Rite accessories – 2 Years Limited                                         |
| • Coil-Rite air springs – Lifetime Limited  | • Brackets, hardware, fittings, air line, and other components – 2 Years Limited |
| • Level-Rite air springs – Lifetime Limited |                                                                                  |

**HOW TO MAKE A WARRANTY CLAIM** — If you purchased your air springs in the U.S. or Canada and believe you have a part with a warrantable defect, call Firestone directly at 1-800-888-0650.

International customers should contact their distributors or dealers directly with any problems.

(\*) Please refer to the “Firestone Limited Lifetime Air Spring Warranty” for details, terms, and conditions.

## **WARRANTY QUESTIONS**

Go to [www.riderite.com/installation-support](http://www.riderite.com/installation-support)

Select “Warranty Info” tab