

# Firestone

## AIRIDE

riderite.com

# INSTALLATION INSTRUCTIONS

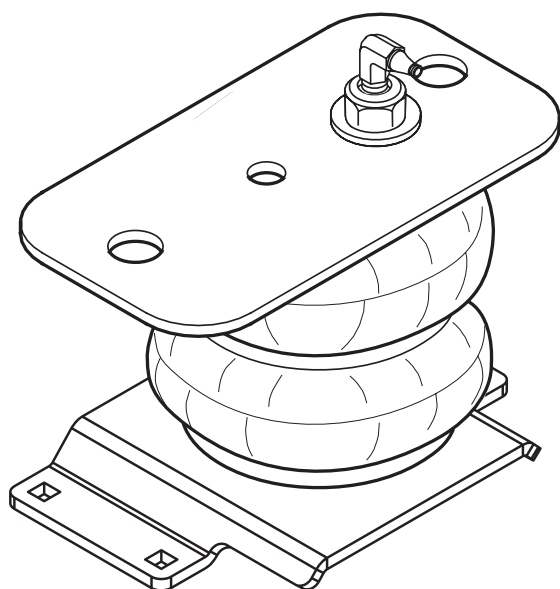

**SECTION 1 - AIR SPRING**

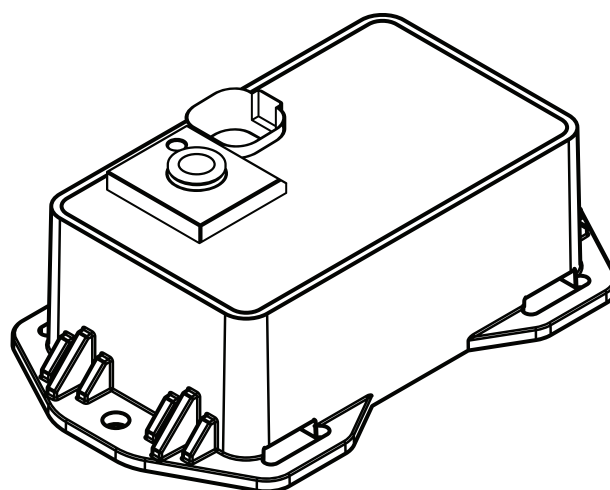

**SECTION 2 - AIR ACCESSORY**



[riderite.com](http://riderite.com)

# INSTALLATION INSTRUCTIONS

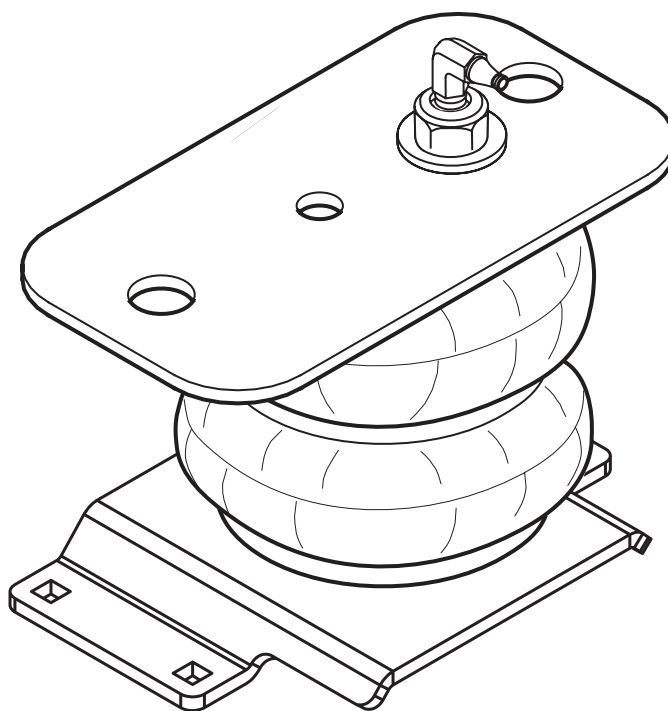

**Firestone**

Firestone Industrial Products

# ! IMPORTANT

PLEASE DON'T HURT YOURSELF, YOUR KIT OR YOUR VEHICLE. TAKE A MINUTE TO READ THIS IMPORTANT INFORMATION.

This kit is to be used on a **pickup truck only**, and **DOES NOT INCREASE YOUR VEHICLE'S MAXIMUM LOAD**.

## **SAFE INSTALLATION**

Please take all safety precautions during installation. A hydraulic jack can fail, and if that happens, you can be seriously hurt, or worse, if you are relying on it to hold up the vehicle. If you use a hydraulic jack, secure jack stands in the appropriate locations and chock any tires still touching the ground.

Wear safety glasses or goggles. Your eyes may be lower than some parts and pieces, and you don't want to lose an eye.

Remove the possibility of any electrical issues by disconnecting the negative battery cable.

## **KIT CLEARANCE**

There must be a minimum of 1/2" clearance around all installed components when the air springs are inflated and under a load. The air springs must flex and expand during operation, so the clearance keeps the kit from rubbing against parts of the vehicle.

## **VEHICLE GVWR**

NEVER exceed the maximum load recommended by the vehicle manufacturer (GVWR). The GVWR can be found in your vehicle's owner's manual or on the data plate on the driver's side door. Consult your local dealership for additional GVWR specifications.

## **INFLATING THE AIR SPRINGS**

When inflating air springs, add air pressure in small quantities, checking air pressure frequently. The air springs have much less air volume than a tire, so they inflate much more quickly.

## **PRESSURE TO LOAD**

The air springs will support approximately 50 lbs. of load for each PSI of inflation pressure (per pair). For example, 50 PSI of inflation pressure will support a load of 2500 lbs. per pair of air springs.

## **APPROPRIATE AIR PRESSURE**

For best ride, use only enough air pressure in the air springs to level the vehicle when viewed from the side (front to rear). This will vary, depending on the load, location of the load, condition of the existing suspension, and personal preference.

## **OPTIONAL T-FITTING**

This kit includes inflation valves and air line tube for each air spring, allowing you to compensate for unbalanced loads. If you prefer a single inflation valve system to provide equal pressure to both air springs, your dealer can supply the optional "T" fitting (Part # 3025 or WRI-760-3461 retail pack).

**ONCE INSTALLED SUCCESSFULLY, FOLLOW THESE PRESSURE REQUIREMENTS FOR THE AIR SPRINGS:**

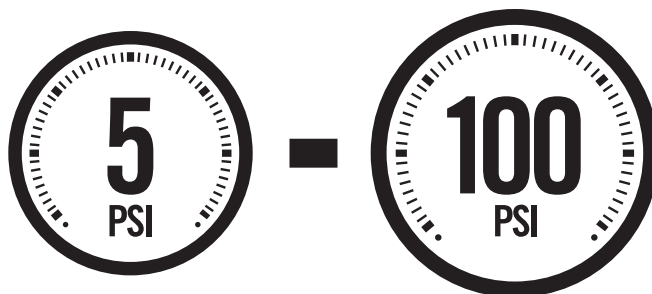





**MINIMUM PRESSURE**

**MAXIMUM PRESSURE (LOADED)**

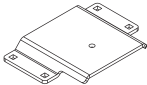

# PARTS

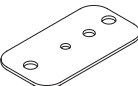
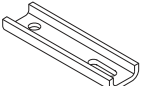
Compare the parts below to your kit. Assure you have all pieces, and organize them for an easier installation.













## MAIN KIT CONTENTS

PT # 6410	 x2 AIR SPRING	PT # 5928	 x2 LOWER BRACKET	PT # 5584	 x2 FUEL PUMP EXTENSION BRACKET
PT # 5542	 x2 UPPER BRACKET	PT # 5086	 x4 LEAF STACK STRAP BRACKET	PT # 9414	 x1 AIR LINE TUBE (18 FEET)

## A24-760-7560 INFLATION VALVE BRACKET KIT

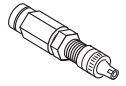
PT # 9483	 x1 NO-DRILL INFLATION VALVE BRACKET	PT # 9488	 x2 LARGE NYLON TIE
-----------	---	-----------	---

## A21-760-2445 HARDWARE PACK

PT # 1057	 x2 1/4" - 20 x 1" HEX BOLT	PT # 3067	 x8 3/8" - 16 FLANGE LOCK NUT	PT # 3371	 x2 5/8" - 18 HEX LOCK NUT
PT # 3069	 x2 3/8" - 16 x 3/4" FLANGE BOLT	PT # 0060	 x2 1/4" LOCK WASHER	PT # 3014	 x8 3/8" - 16 x 3 1/2" CARRIAGE BOLT
PT # 0075	 x2 5/8" FLAT WASHER	PT # 3033	 x4 5/16" FLAT WASHER	PT # 9036	 x6 RED NYLON TIE
PT # 3032	 x2 INFLATION VALVE AND VALVE CAP ASSEMBLY	PT # 0864	 x4 1/4" FLAT WASHER	PT # 0899	 x2 THERMAL SLEEVE
PT # 3128	 x2 SWIVEL AIR FITTING	PT # 0057	 x2 1/4" HEX NUT		

# CONTENTS AND OVERVIEW

PAGE **4** REMOVE JOUNCE BUMPER & UNFASTEN FUEL PUMP CONTROL

PAGE **5** FASTEN AIR SPRING TO LOWER BRACKET

PAGE **6** PREPARE THE UPPER BRACKET

PAGE **7** AIR SPRING ASSEMBLY INSTALLATION

PAGE **8** LEAF STACK STRAP BRACKET INSTALLATION

PAGE **9** REINSTALL THE FUEL PUMP CONTROL

PAGE **10** AIR LINE TUBE & INFLATION VALVE INSTALLATION

PAGE **11** INSTALL & ROUTE AIR LINE TUBE

PAGE **12** CHECKING THE SYSTEM

PAGE **13** FIXING AN AIR LEAK

PAGE **14** FINISHING THE INSTALLATION

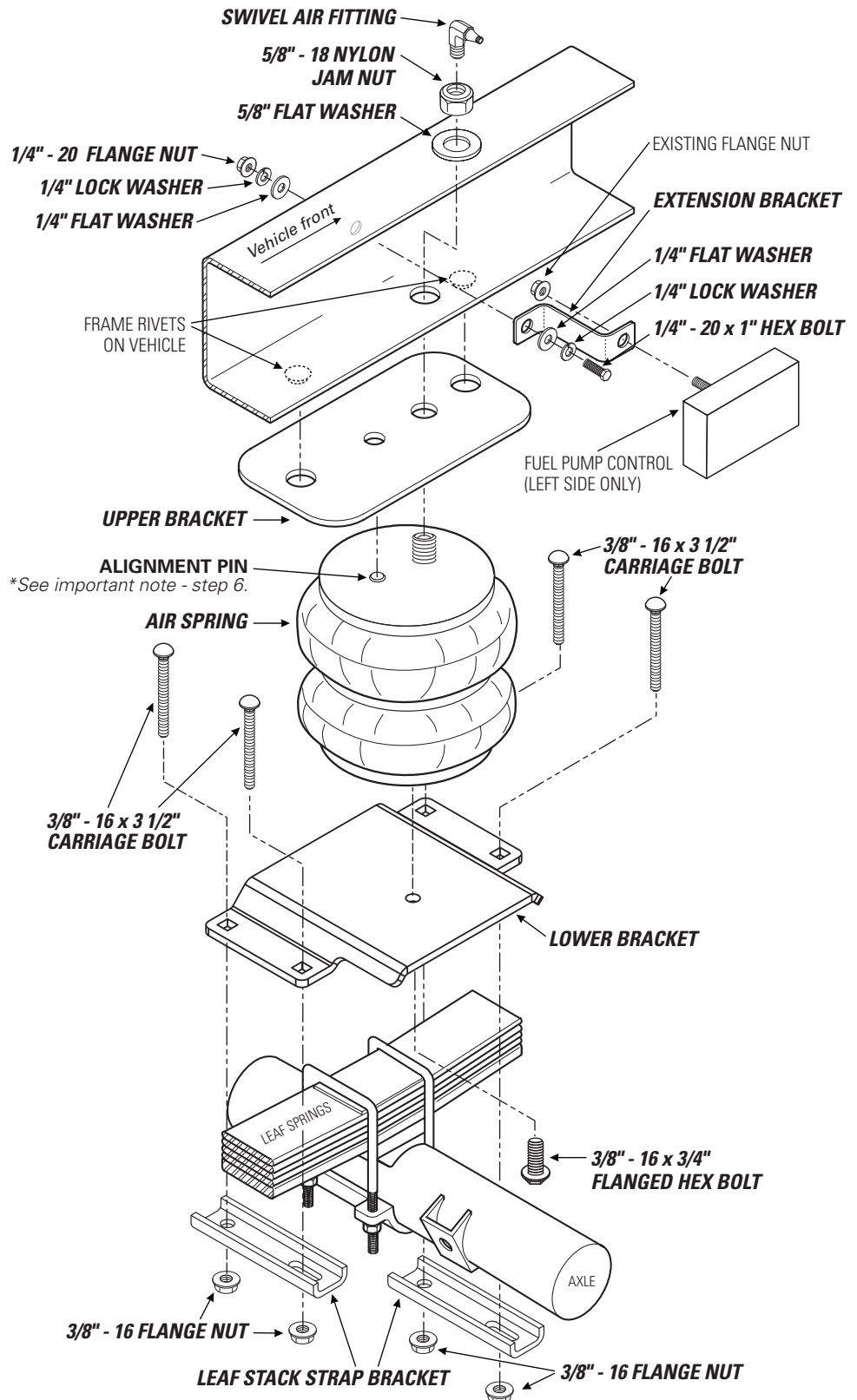

# REMOVE EXISTING JOUNCE BUMPER

1



START THE INSTALLATION ON THE LEFT SIDE OF THE VEHICLE WHEN FACING FORWARD.

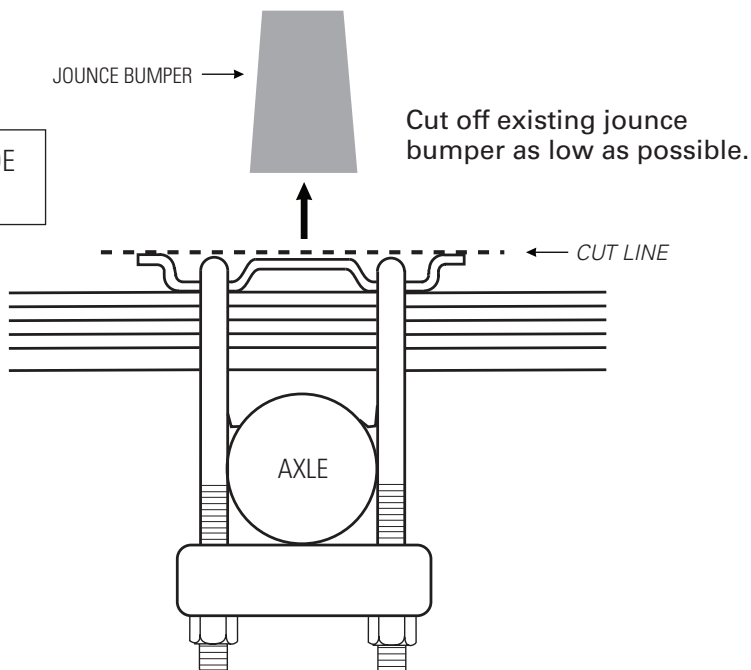

# UNFASTEN FUEL PUMP CONTROL & PREPARE EXTENSION BRACKET

2

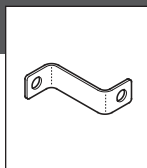

## LEFT SIDE ONLY

Unfasten fuel pump control from frame.

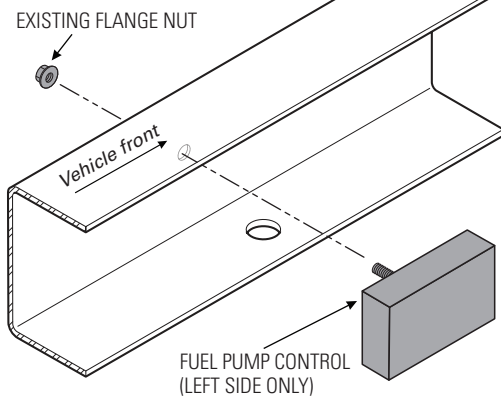

Use existing flange nut to fasten the fuel pump control to the extension bracket. Do not yet fasten the extension bracket to the vehicle frame.

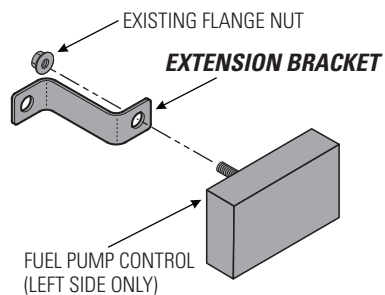

# 3

## FASTEN AIR SPRING TO LOWER BRACKET

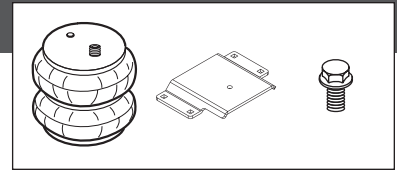

Install the air spring to the lower bracket.

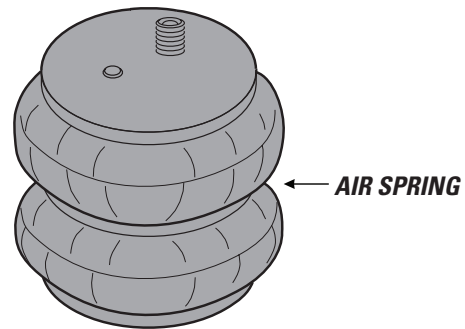

**AIR SPRING**

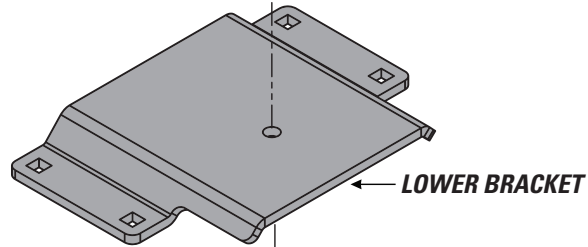

**LOWER BRACKET**

**3/8" - 16 x 3/4"  
FLANGED HEX BOLT**



DO NOT FULLY TIGHTEN THE BOLT AT THIS STAGE. TORQUE TO SPEC IN STEP 6.

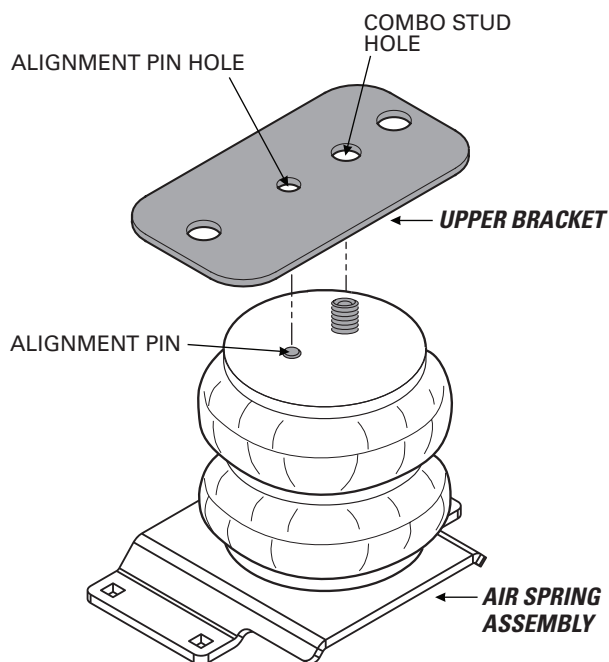
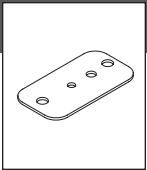

Place the upper bracket on top of the air spring, as shown.

**Make sure the alignment pin is fully seated in the alignment pin hole in the upper bracket.**

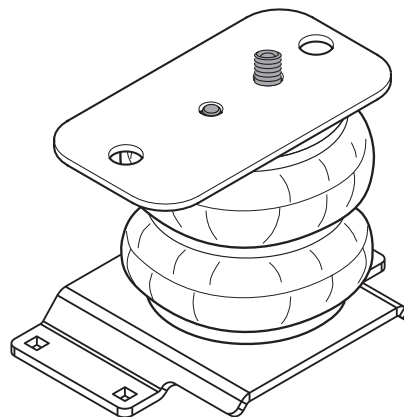



# 5

## INSTALL AIR SPRING ASSEMBLY

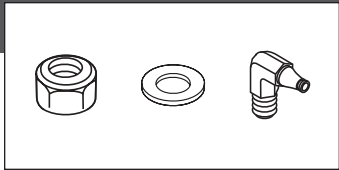

**1** Follow guidelines below to dry fit assembly. Make alignment marks as shown.

**2** Remove assembly and match alignment marks you made.

**3** Fully tighten the 3/8"-16 x 3/4" flanged hex head bolt on the bottom of the lower bracket.

**4** Insert the combo stud on top of the air spring into the hole in the vehicle frame.

**5** Make sure two holes in the upper bracket align with the frame rivets on the vehicle.

**6** Securely fasten the top of the air spring and install the swivel air fitting, as shown.



THE EMERGENCY BRAKE BRACKET MAY NEED TO BE SLIGHTLY BENT TO ALLOW PROPER CLEARANCE.

**SWIVEL AIR FITTING**  
Thread onto inside of air combo stud.  
*Tighten until threadlock coating is fully engaged*  
**DO NOT OVERTIGHTEN.**

**5/8" - 18 NYLON JAM NUT**  
Thread onto outside of air combo stud.

**5/8" FLAT WASHER**

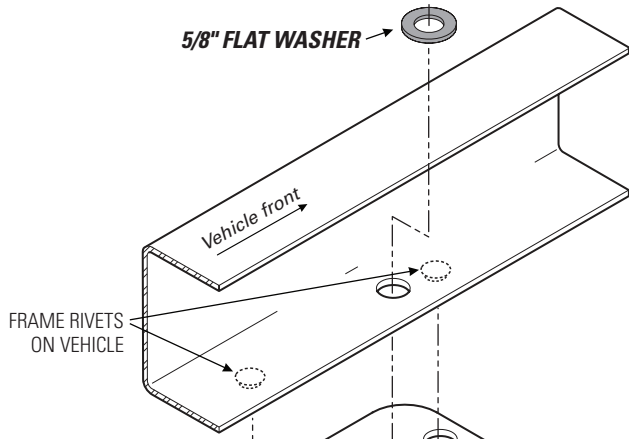

NOTE: Alignment pin must be correctly seated into alignment pin hole on the upper bracket.



ALIGNMENT PIN ON AIR SPRING MUST BE INSTALLED TO FULLY SEAT INTO THE ALIGNMENT HOLE IN THE UPPER BRACKET. FAILURE TO DO SO WILL CAUSE IT TO BE PUSHED INTO THE BEAD PLATE, CREATING AN AIR LEAK, AND RESULTING IN AN AIR SPRING FAILURE THAT IS **NOT WARRANTABLE. THE ALIGNMENT PIN CANNOT HOLD 2,500 LBS! IT IS USED FOR ALIGNMENT ONLY!**

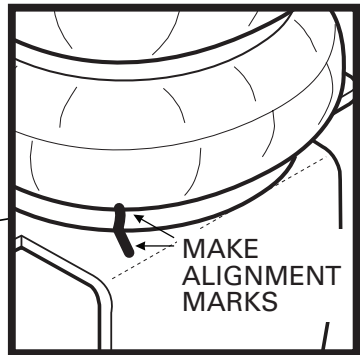

Carriage bolt holes in lower bracket fall on either side of the leaf spring stack.

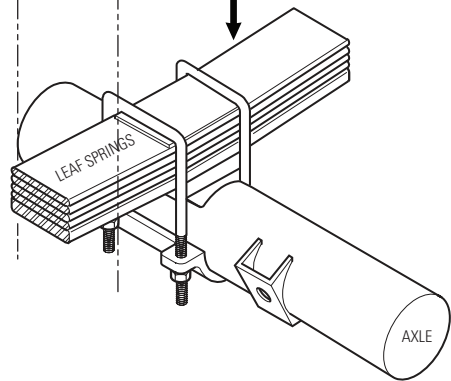

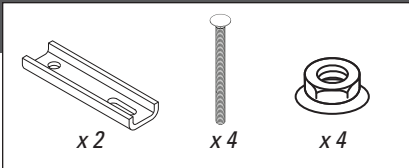

**1** Insert carriage bolts into holes in lower bracket.

**2** Install the leaf stack strap bracket onto the carriage bolts, under the leaf spring stack.

**3** Fasten the leaf stack strap brackets to the carriage bolts, as shown.

**4** Check for air spring clearance and adjust, if necessary.

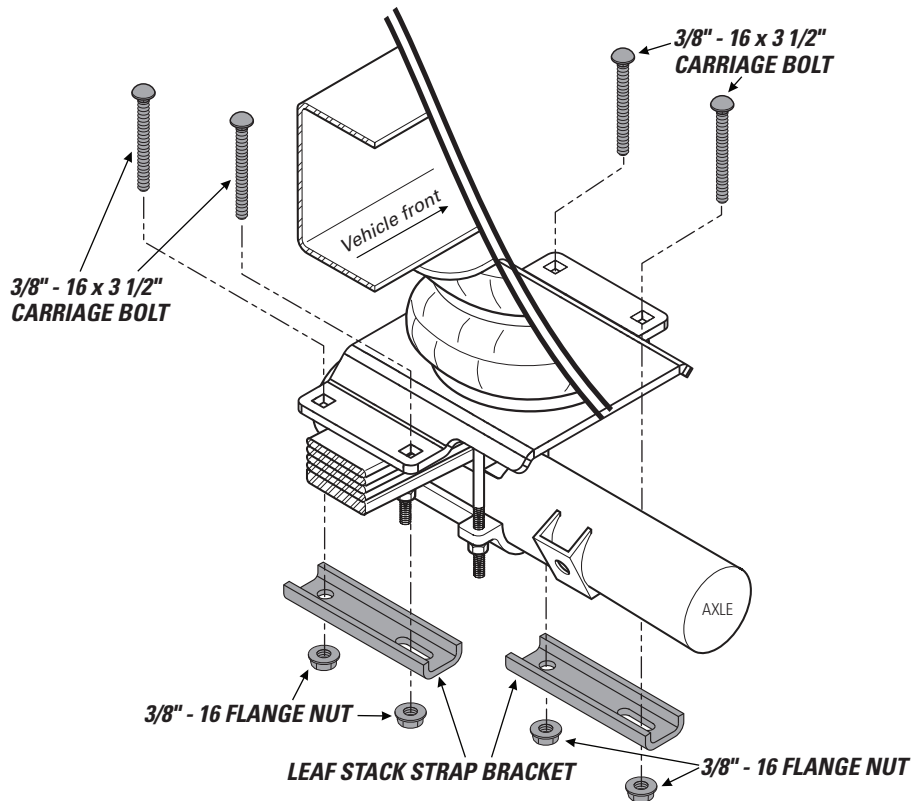

Alternate tightening of flange nuts to draw leaf stack strap brackets evenly to the leaf spring stack.



USE YOUR HAND TO CHECK FOR THE PROPER CLEARANCE AROUND THE AIR SPRING. IF YOUR HAND DOES NOT FIT BETWEEN THE AIR SPRING AND OTHER COMPONENTS, IT WILL RUB!

# 7

## REINSTALL THE FUEL PUMP CONTROL

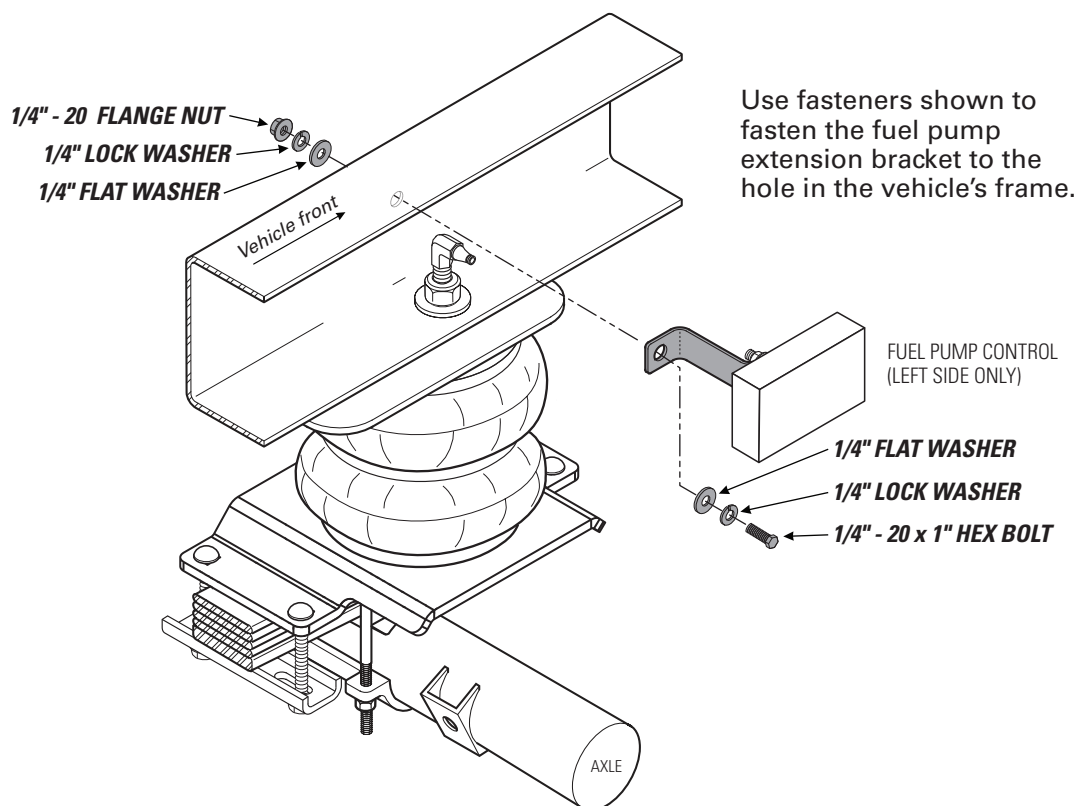
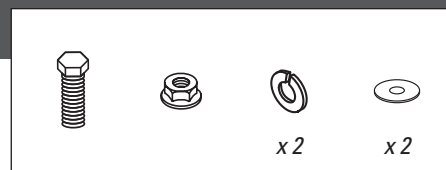

**AWESOME!** You're done with the left side. The right side installation is the same, with the exception of the fuel pump bracket. Go complete steps 1-7 for the right side, then continue to step 8.

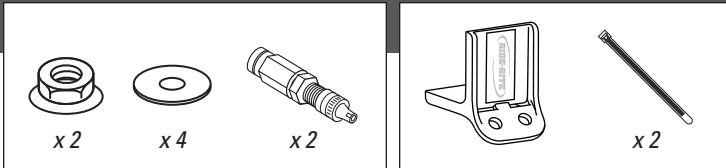

IF USING THE OPTIONAL NO-DRILL INFLATION VALVE BRACKET, CHOOSE OPTION 1. IF DRILLING, CHOOSE OPTION 2. **INFLATION VALVES MUST BE ACCESSIBLE BY AN AIR CHUCK.**

**1** Secure the Air Inflation Valve Bracket to a protected, secure location. **PROCEED TO STEP 3.**

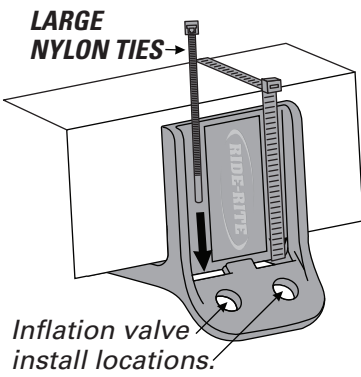

**2** Select a protected location to install the Inflation Valves, such as the bumper or the body of the vehicle.

Drill two 5/16" holes for Inflation Valve install locations.

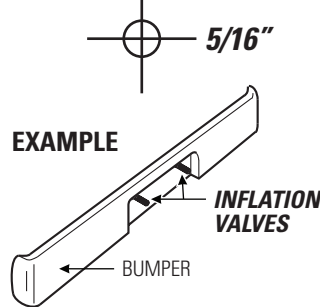

**3** Install Inflation Valve assembly as shown.

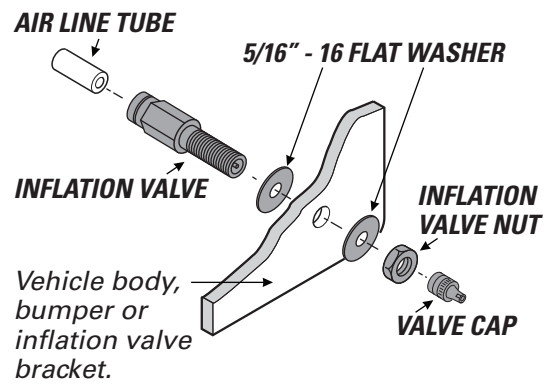

**1** Match air line tube ends.

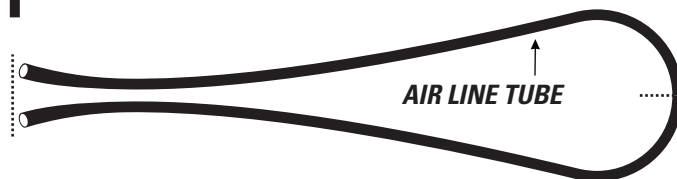

**2** Find center of air line tube, make a square cut with tube cutter or sharp utility knife.

**DO**

Make sure the cut is as square as possible. Use a tube cutter or sharp utility knife.

**DON'T**

Fold or kink the air line tube. Cut the air line tube at an angle. Use pliers, scissors, snips, saws, or side cutters.

**PROPER AND IMPROPER CUTS IN THE AIR LINE TUBE**

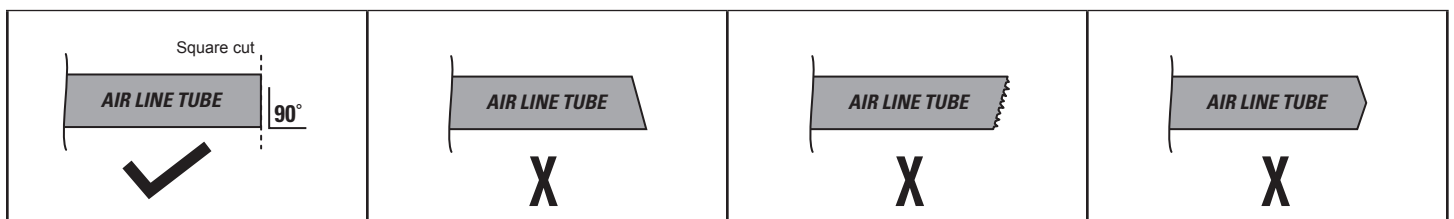

# 10

## INSTALLING AIR LINE TUBE INTO AIR FITTINGS AND INFLATION VALVE

**1** Insert end of air line tube into air fitting.

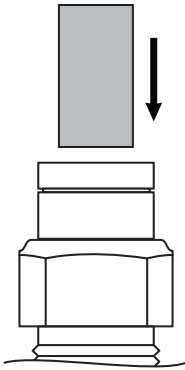

**2** Push air line tube into air fitting as far as possible.

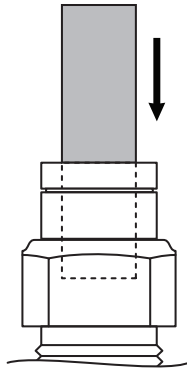

**3** Gently pull on the air line tube to check for a secure fit.

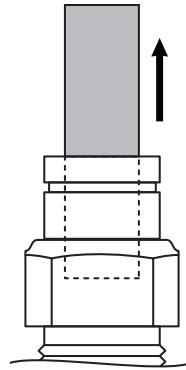

**4** To remove, push down collar and gently pull air line tube away.

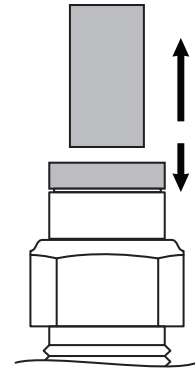

**Removal Tip:** Use a 1/4", 5/16", or 6mm open-ended wrench to push the collar down.

# 11

## ROUTE AND SECURE AIR LINE TUBES

Air line tube routes will vary, depending on your truck, and requires you to choose the best path from the air springs to the inflation valves. Use the instructions below to help you choose.

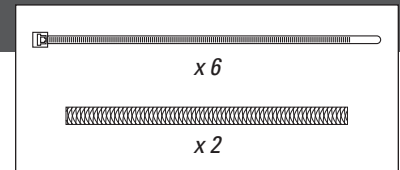

# DO

Select routes protected from heat, debris, and sharp edges. Use thermal shields near heat sources. Use nylon ties to secure the air line tube.

# DON'T

Bend or sharply curve air line tubes. Leave air line tube exposed to sharp edges. Use unnecessary lengths of air line tube. Route air line tube near moving parts. Let air line tube hang unsecured from vehicle. Scar air line tube while routing.

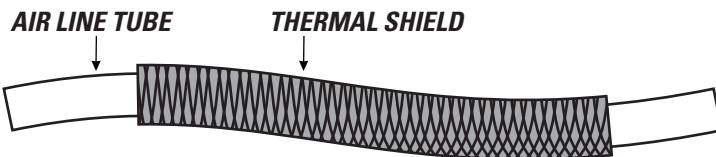

USE SUPPLIED THERMAL SHIELDS WHEN AIR LINE TUBE RUNS **WITHIN 6 INCHES** OF HEAT SOURCES.

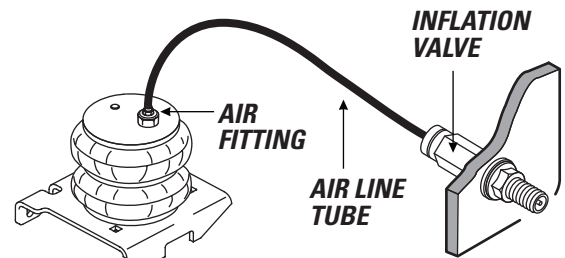

- 1** Place an air chuck onto the inflation valve and fill the system to **70 PSI**.

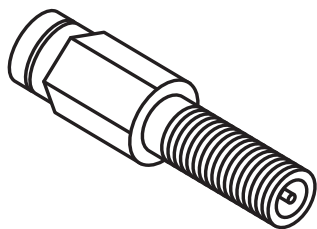

AIR SPRINGS INFLATE QUICKLY. CHECK AIR PRESSURE WHILE INFLATING.

- 2** Spray fittings with soap and water mixture.



- 3** Observe bubbles.

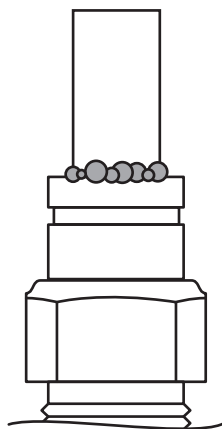

**SMALL SOAP BUBBLES  
THAT DO NOT EXPAND**

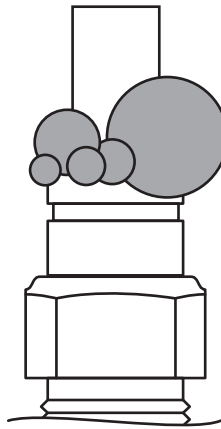

**SOAP BUBBLES  
THAT EXPAND**



# NO LEAKS?

Congratulations! Continue to step 14 to finish installation. Review the Operating Instructions.

# LEAK?

Bummer. Continue to step 13 to fix the leak.

- 1** Press the air valve on end of inflation valve to release all air pressure.

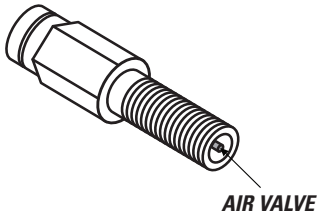

EXHAUST ALL AIR FROM THE SYSTEM PRIOR TO RELEASING AIR LINE TUBES FROM AIR FITTINGS.

#### LEAK AT AIR LINE TUBE AND AIR FITTING

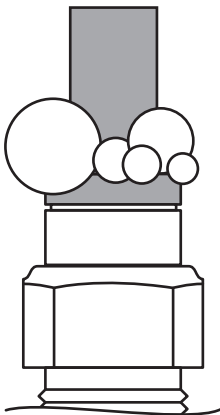

Release air line tube (see page 11). Review proper cuts and procedures in step 9. Repeat steps 10 and 12.

#### LEAK AT BASE OF AIR FITTING ON AIR SPRING

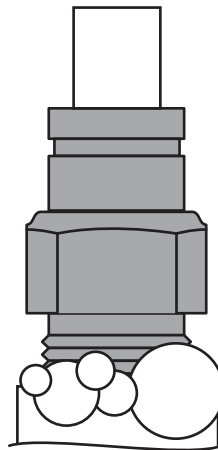

Tighten air fitting one turn or until leak stops.

#### LEAK OUT OF THE VALVE CORE ON INFLATION VALVE

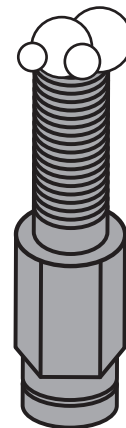

Tighten valve core with valve core wrench on inflation valve cap.

## STILL HAVE A LEAK?

Refer to the Troubleshooting section of the Instruction Manual. If the leak persists, or if there is an issue with a leaking part, visit [riderite.com](http://riderite.com).

**SAFELY RETURN VEHICLE TO OPERATIVE STATE**

If you removed any wheels during installation, install the wheels and torque the lug nuts to the manufacturer's specifications.

Safely remove any jack stands and wheel chocks used during installation.

Re-attach the negative battery cable.

**DOUBLE-CHECK AIR SPRING CLEARANCE**

Check the air springs once again for the proper 1/2" minimum clearance. Perform clearance check again when vehicle is under load.

**VEHICLE GVWR**

NEVER exceed the maximum load recommended by the vehicle manufacturer (GVWR). The GVWR can be found in your vehicle's owner's manual or on the data plate on the driver's side door. Consult your local dealership for additional GVWR specifications.

**READ AND UNDERSTAND THE OPERATING INSTRUCTIONS**

The Ride-Rite system can improve handling and comfort. Take the time to learn how to properly use and maintain your investment by reading the Operating Instructions.



USE YOUR HAND TO CHECK FOR THE PROPER CLEARANCE AROUND THE AIR SPRING. IF YOUR HAND DOES NOT FIT BETWEEN THE AIR SPRING AND OTHER COMPONENTS, IT WILL RUB!

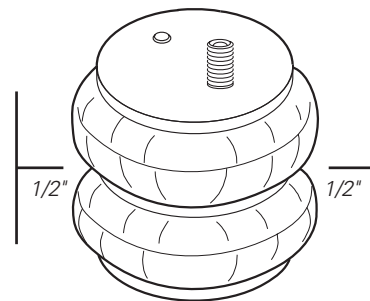

# ! IMPORTANT

**A MINIMUM OF 5 PSI MUST BE MAINTAINED IN THE AIR SPRINGS AT ALL TIMES**

Too much air pressure in the air springs will result in a firmer ride, while too little air pressure will allow the air springs to bottom out over rough conditions, and will not provide the improvement in handling that is possible.



MINIMUM PRESSURE



MAXIMUM PRESSURE (LOADED)





[riderite.com](http://riderite.com)

## BEFORE YOU DRIVE, CONFIRM THE FOLLOWING:

- Do you have a minimum of 5PSI in your air springs?
- Are your air springs standing 5 1/2" - 6 1/2" tall?
- Are your air springs properly aligned, left-to-right and front-to-back?
- Are your nuts and bolts tight?
- Put your paper work back into the sleeve and keep it in your glove compartment for future reference.
- You've been bagged...and now your suspension is Airide equipped! Show it off with the supplied decal!

5 1/2" - 6 1/2"

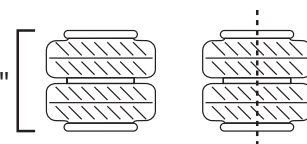

## NEED INSTALLATION HELP?

Email us at [rrtech@fsip.com](mailto:rrtech@fsip.com). Please include photos to help us better diagnose and understand any problems you may be experiencing.

**Firestone**  
Firestone Industrial Products

CONNECT WITH US



FirestoneIP



Firestone Ride-Rite



[riderite.com](http://riderite.com)

# INSTALLATION INSTRUCTIONS

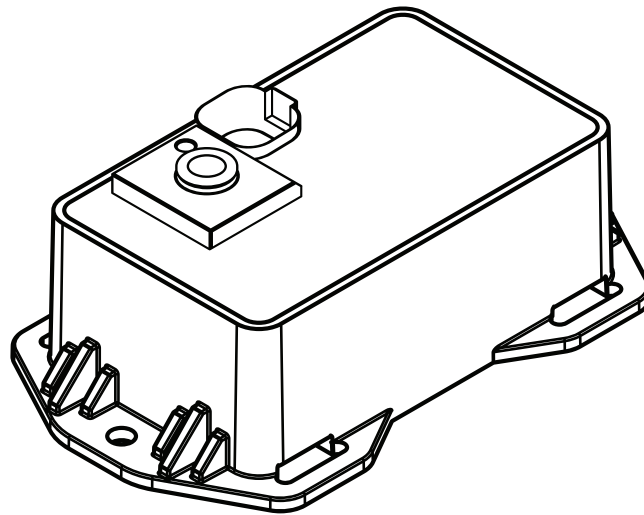

**Firestone**

Firestone Industrial Products

# **IMPORTANT**

*PLEASE DON'T HURT YOURSELF, THE KIT, OR YOUR VEHICLE. TAKE A MINUTE TO READ THIS IMPORTANT INFORMATION.*

## **SAFE INSTALLATION**

Please take all safety precautions during installation. A hydraulic jack can fail, and if that happens, you can be seriously hurt, or worse, if you are relying on it to hold up the vehicle. If you use a hydraulic jack, secure jack stands in the appropriate locations and chock any tires still touching the ground.

Wear safety glasses or goggles. Your eyes may be lower than some parts and pieces, and you don't want to lose an eye.

Remove the possibility of any electrical issues by disconnecting the negative battery cable.

## **VEHICLE GVWR**

NEVER exceed the maximum load recommended by the vehicle manufacturer (GVWR). The GVWR can be found in your vehicle's owner's manual or on the data plate on the driver's side door. Consult your local dealership for additional GVWR specifications.

## **PRESSURE TO LOAD**

Be sure to review the load limits noted in the air spring kit installation instructions (sold separately).

## **APPROPRIATE AIR PRESSURE**

For best ride, use only enough air pressure in the air springs to level the vehicle when viewed from the side (front to rear). This will vary, depending on the load, location of the load, condition of the existing suspension, and personal preference.

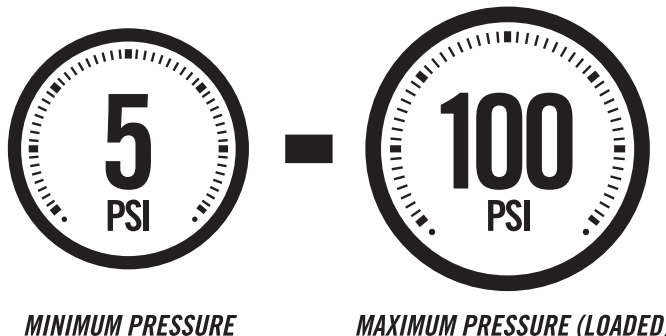

***ONCE INSTALLED SUCCESSFULLY, FOLLOW THESE PRESSURE REQUIREMENTS FOR THE AIR SPRINGS:***



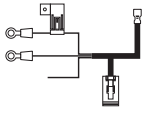
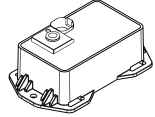
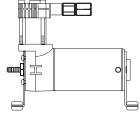

# PARTS

Compare the parts below to your kit. Assure you have all pieces, and organize them for an easier installation.









## MAIN KIT CONTENTS

PT # 9534	 x1 WIRE HARNESS	PT # 9535	 x1 ECU	PT # 9523	 x1 AIR COMPRESSOR KIT
				PT # 9414	 x1 AIR LINE TUBE (18 FEET)

## A24-760-7560 INFLATION VALVE BRACKET KIT

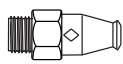
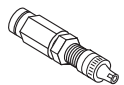
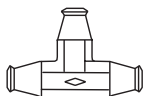
PT # 9483	 x1 NO-DRILL INFLATION VALVE BRACKET	PT # 9488	 x2 LARGE NYLON TIE
-----------	---	-----------	---

## A21-760-2610 HARDWARE PACK

PT # 3087	 x4 10-32 x 1" MACHINE SCREW	PT # 3093	 x2 10-32 x 3/4" MACHINE SCREW	PT # 3086	 x10 3/16" FLAT WASHER
PT # 3088	 x6 10-32 NYLOCK NUT	PT # 3055	 x1 1/8 NPT PUSH-TO-CONNECT STRAIGHT FITTING	PT # 3032	 x1 INFLATION VALVE AND VALVE CAP ASSEMBLY
PT # 3025	 x3 1/4" PUSH-TO-CONNECT TEE	PT # 3421	 x1 10-16 x 3/4" SELF-TAPPING SCREW	PT # 9036	 x8 RED NYLON TIE
PT # 9488	 x2 LARGE NYLON TIE	PT # 0899	 x2 THERMAL SLEEVE		

# CONTENTS AND OVERVIEW

- PAGE **4** **PLANNING THE INSTALL**

---

- PAGE **5** **PREPARE THE AIR COMPRESSOR**

---

- PAGE **6** **DRILL HOLES FOR AIR COMPRESSOR AND ECU**

---

- PAGE **7** **INSTALL THE AIR COMPRESSOR AND ECU**

---

- PAGE **8** **INSTALL THE WIRE HARNESS**

---

- PAGE **9** **INSTALL THE AIR LINE TUBES**

---

- PAGE **10** **OPTIONAL INFLATION VALVE INSTALLATION**

---

- PAGE **11** **INSTALL THE AIR FILTER AND CLEAN UP**

---

- PAGE **12** **CONNECTING TO THE APP**

---

- PAGE **13** **TEST THE SYSTEM**

---

- PAGE **14** **FIX AN AIR LEAK**

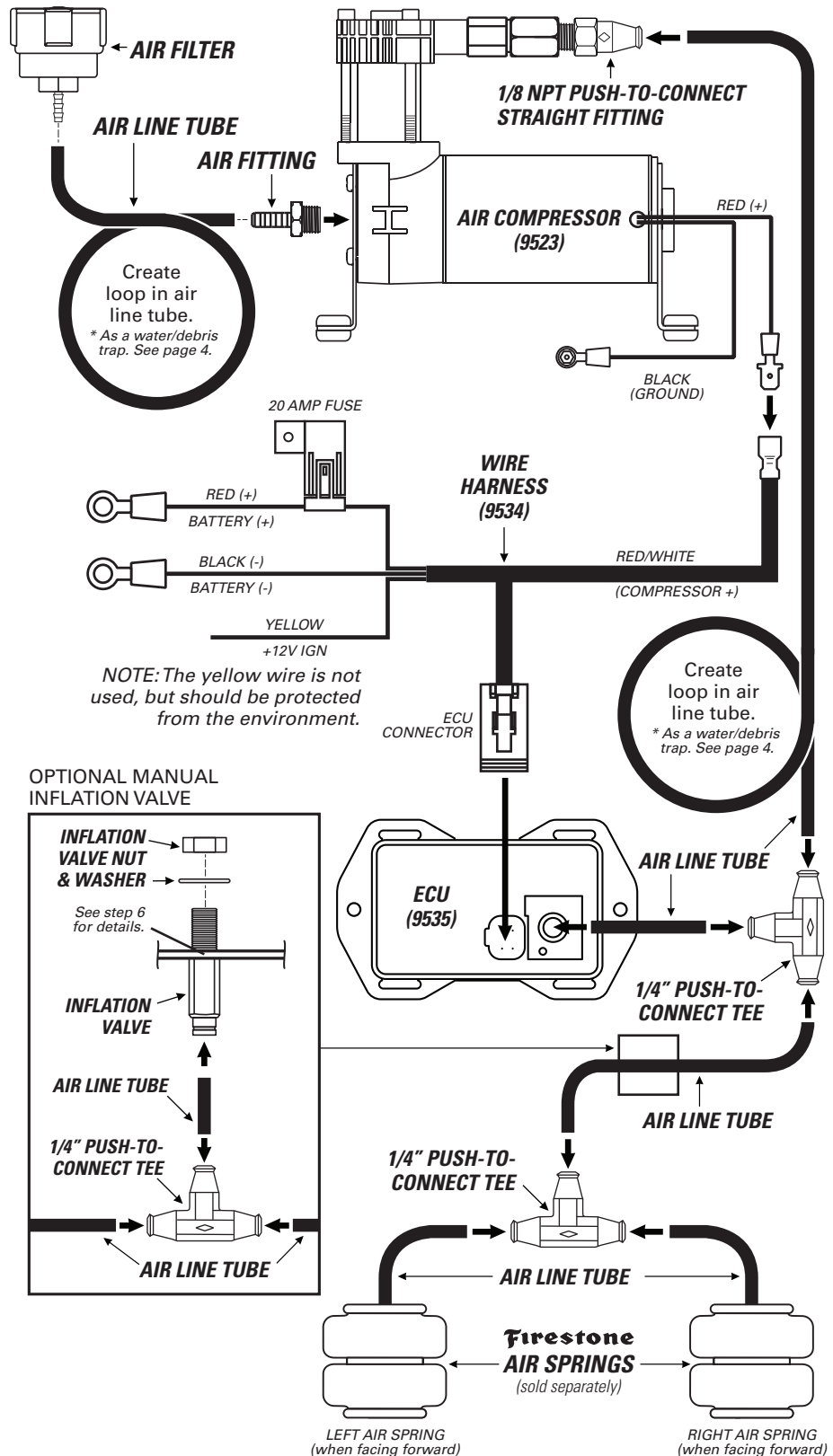

# PLANNING THE INSTALL

THESE PLANNING STEPS WILL HELP YOU SAVE TIME AND WILL MAKE THE INSTALLATION EASIER.

## **DETERMINE THE MOUNTING LOCATION FOR THE AIR COMPRESSOR**

- Provides ample air flow and is protected from airborne debris and moisture.
- Mount close enough to the ECU to allow wire harness connections to reach.
- If using the optional Firestone air accessory mounting kit, consider the guidelines above, and follow the kit's instructions.

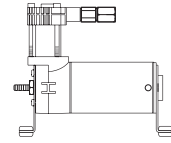

## **DETERMINE THE MOUNTING LOCATION FOR THE ECU**

- Mount close enough to the air compressor to allow wire harness connections to reach.
- Allow room for air line tube to connect to the air fittings on the ECU.
- Allow room for the 4-pin ECU connector to connect to the ECU.
- Allow room for the air line tube to run without sharp curves or bends.
- Using supplied fasteners shown in step 3 is recommended. If no other mounting option is available, see the sidebar on step 2 for using the large Nylon ties.
- Select a location that is solid and secure on the body or frame of the vehicle, away from any moving parts, electrical or any other lines.

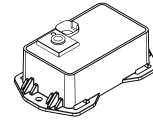

## **PLAN INSTALLATION ROUTES FOR WIRING AND AIR LINES**

- Make sure the wire harness and air line tubes are not exposed to sharp metal edges that can damage them.
- Use supplied thermal sleeves on air line tubes when routing near heat sources.
- Use supplied Nylon ties to secure air line tubes and wire harness to the vehicle.
- Make a loop in the air line tube where shown. This creates a water/debris trap that protects the air compressor.
- Measure twice, cut once!

## **TAPE ALL ELECTRICAL CONNECTIONS**

- Use electrical tape to appropriately secure and protect all electrical connections.

## **USING PUSH-TO-CONNECT FITTINGS FOR AIR LINES**

Your kit includes push-to-connect fittings to connect the air line tubes to hardware. Use the instructions below when using the air line tubes.

- 1** Insert end of air line tube into air fitting.

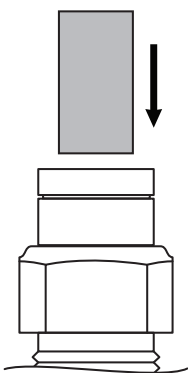

- 2** Push air line tube into air fitting as far as possible.

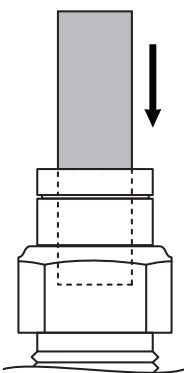

- 3** Gently pull on the air line tube to check for a secure fit.

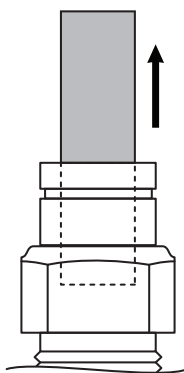

- 4** To remove, push down collar and gently pull air line tube away.

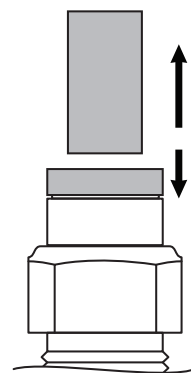

**Removal Tip:** Use a 1/4", 5/16", or 6mm open-ended wrench to push the collar down.

# 1

## PREPARE THE AIR COMPRESSOR

*NOTE: Air compressor can be mounted facing any direction.*

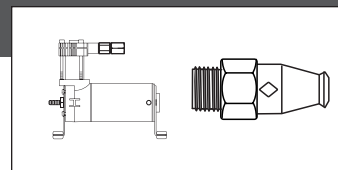

- 1 Install 1/8 NPT push-to-connect straight fitting on the check valve.

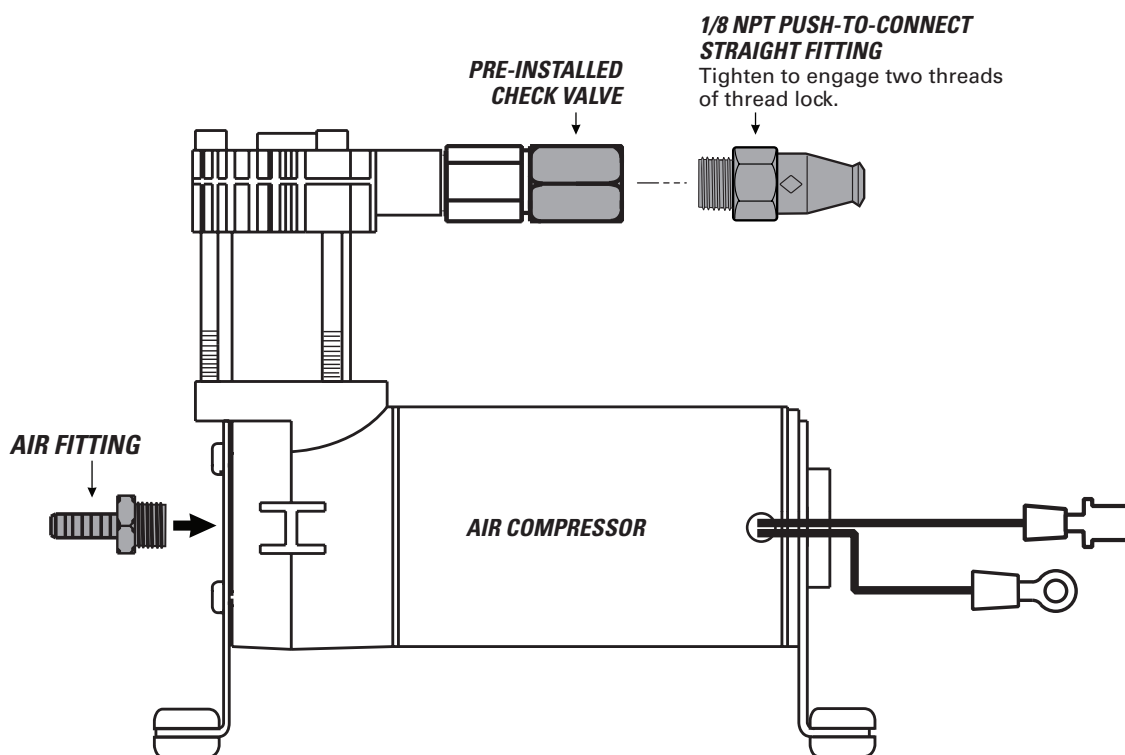

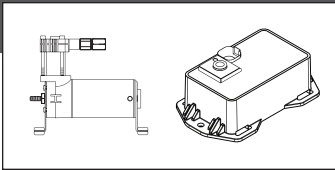

CHECK SURROUNDING AREA AND BACK SIDE OF MOUNTING LOCATION TO AVOID DRILLING INTO EXISTING LINES OR WIRING.



IF YOU ARE USING THE OPTIONAL FIRESTONE AIR ACCESSORY MOUNTING KIT, SKIP THIS STEP AND REFER TO THE MOUNTING KIT'S INSTRUCTIONS.

Drill within reach of the ground wire ring terminal on body or frame of vehicle. **AIR ACCESSORY MOUNTING KIT CANNOT BE USED AS A GROUNDING LOCATION FOR THE AIR COMPRESSOR.**

**1** Using the air compressor and ECU as templates, mark drill locations as shown with a punch or marking tool.

**2** Mark air compressor ground wire fastening location within reach of the ground wire ring terminal.

**3** Drill 3/16" diameter holes. Remove any burrs and debris from drill holes.

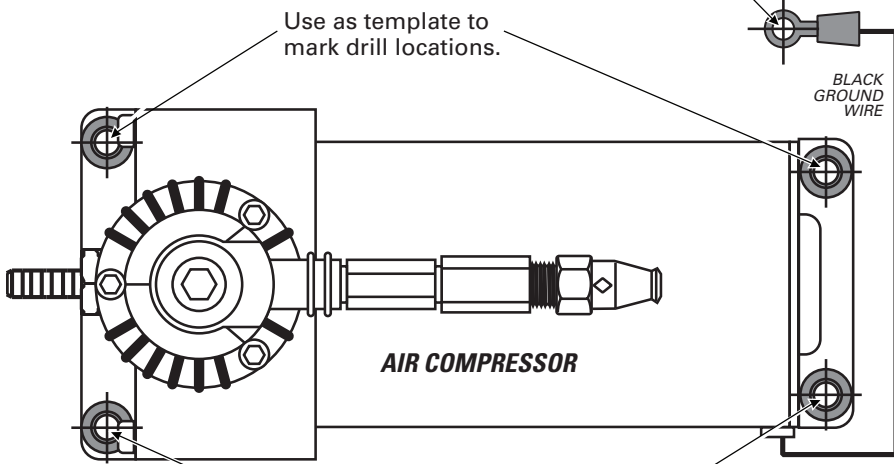

ASSURE THAT YOU INSTALL THE AIR COMPRESSOR AND ECU CLOSE ENOUGH SO THE CONNECTORS ON THE WIRE HARNESS WILL REACH THEM BOTH.

Use as template to mark drill locations.

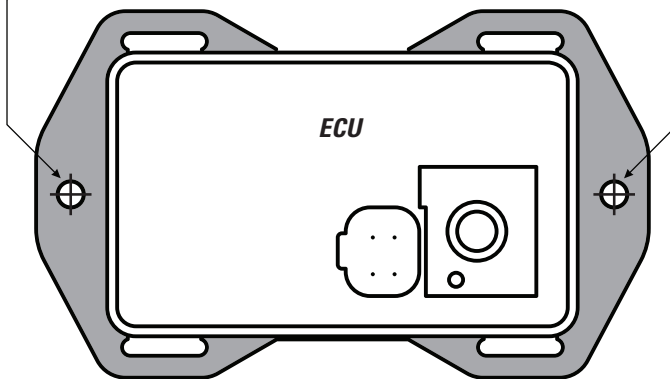

**OPTIONAL ECU MOUNTING**

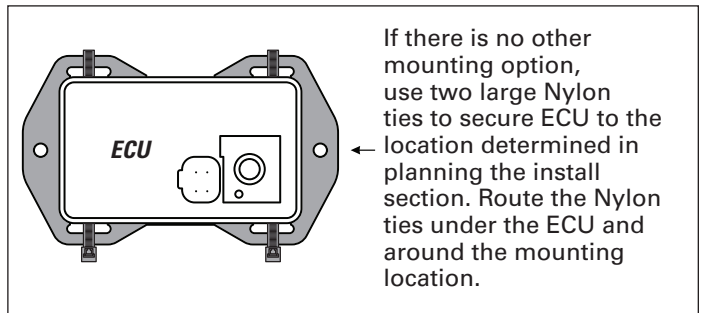

If there is no other mounting option, use two large Nylon ties to secure ECU to the location determined in planning the install section. Route the Nylon ties under the ECU and around the mounting location.



# 3

## INSTALL THE AIR COMPRESSOR AND ECU

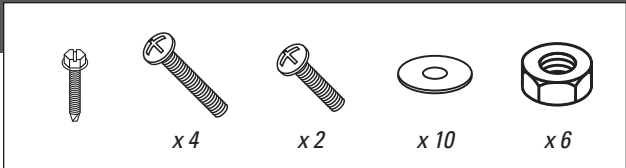

DO NOT OVER TIGHTEN MOUNTING BOLTS AND NUTS ON THE AIR COMPRESSOR. TOO MUCH TORQUE CAN CRUSH THE BRASS INSERTS AND RUBBER ISOLATORS.

**1** Mount the air compressor to the drill hole location using the supplied fasteners. DO NOT OVERTIGHTEN.

**2** Mount the ECU to the drill hole location using the supplied fasteners.

**3** Mount the black ground wire ring terminal using the supplied fasteners. Assure that the ring terminal makes a solid contact with bare metal for a proper ground.

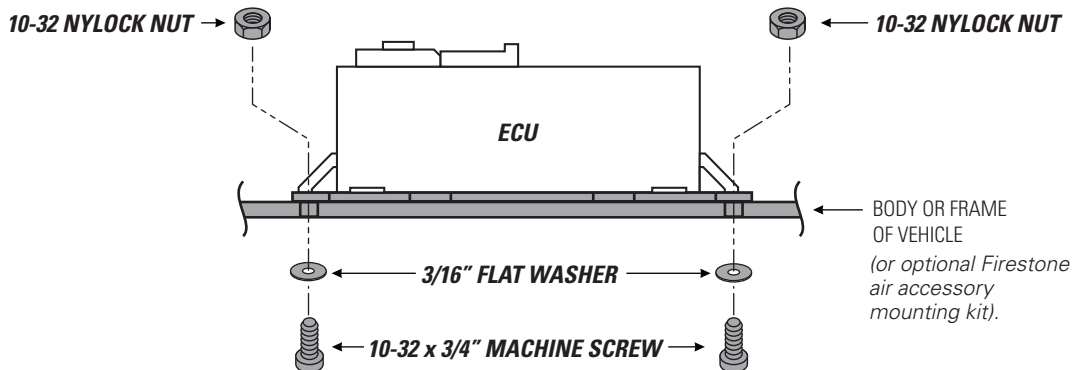
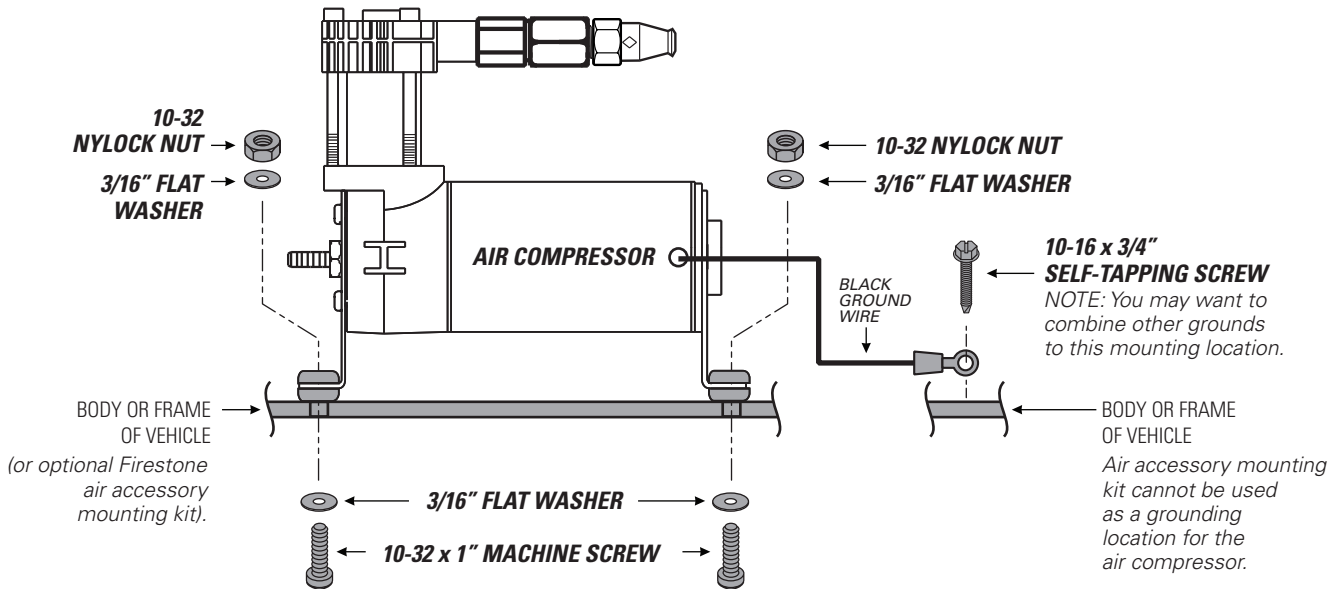

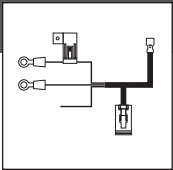

**1** Route the wire harness in the most protected manner possible, and securely make all connections as shown.

**2** The yellow wire is not used. Wrap or wire nut it to protect it from the environment.

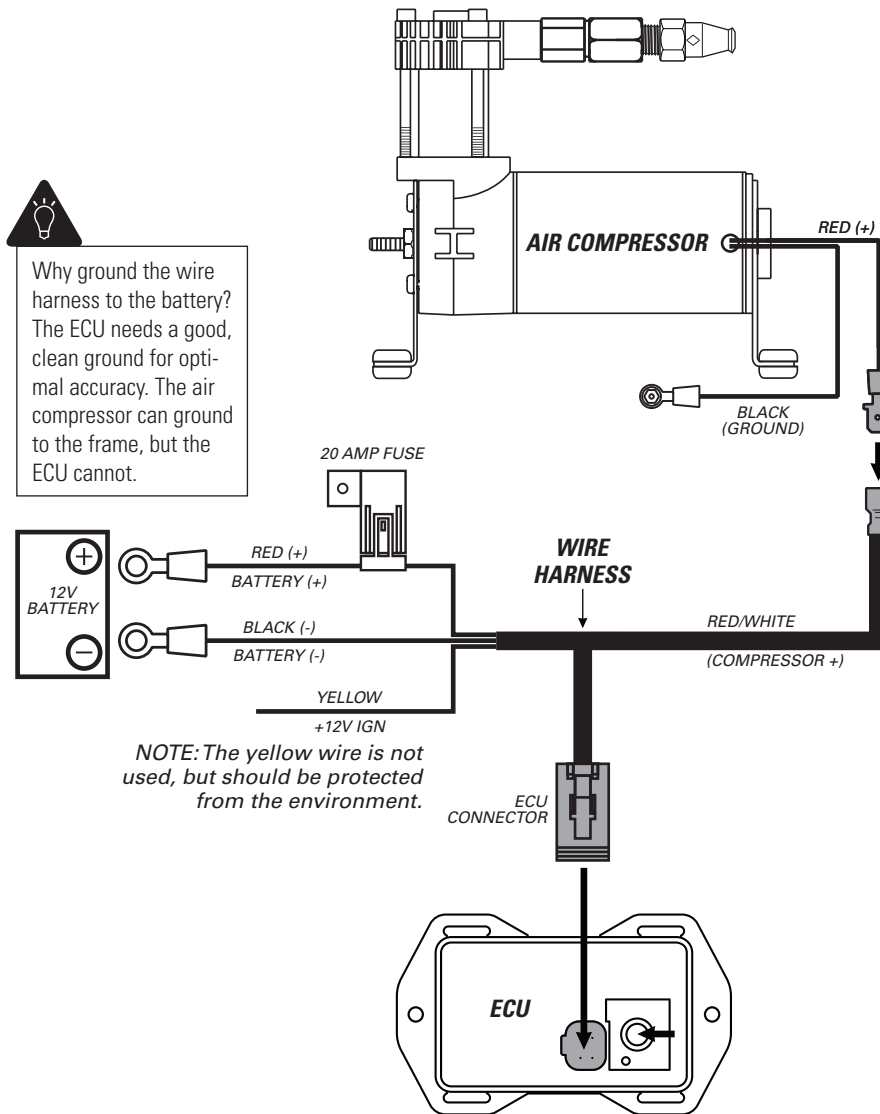

# 5

## INSTALL AIR LINE TUBES



EXHAUST ALL AIR FROM THE SYSTEM PRIOR TO RELEASING AIR TUBES FROM AIR FITTINGS.

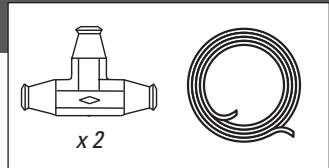

**1** Route the air line tube from 1/8 NPT push-to-connect straight fitting on the top of the air compressor to the first 1/4" push-to-connect tee.

**2** From the 1/4" push-to-connect tee, route air line tube to the ECU, as shown.

**3** Route air line tube from each air spring and connect to a 1/4" push-to-connect tee, as shown.

**4** Route air line tube to connect the two 1/4" push-to-connect tees, as shown.

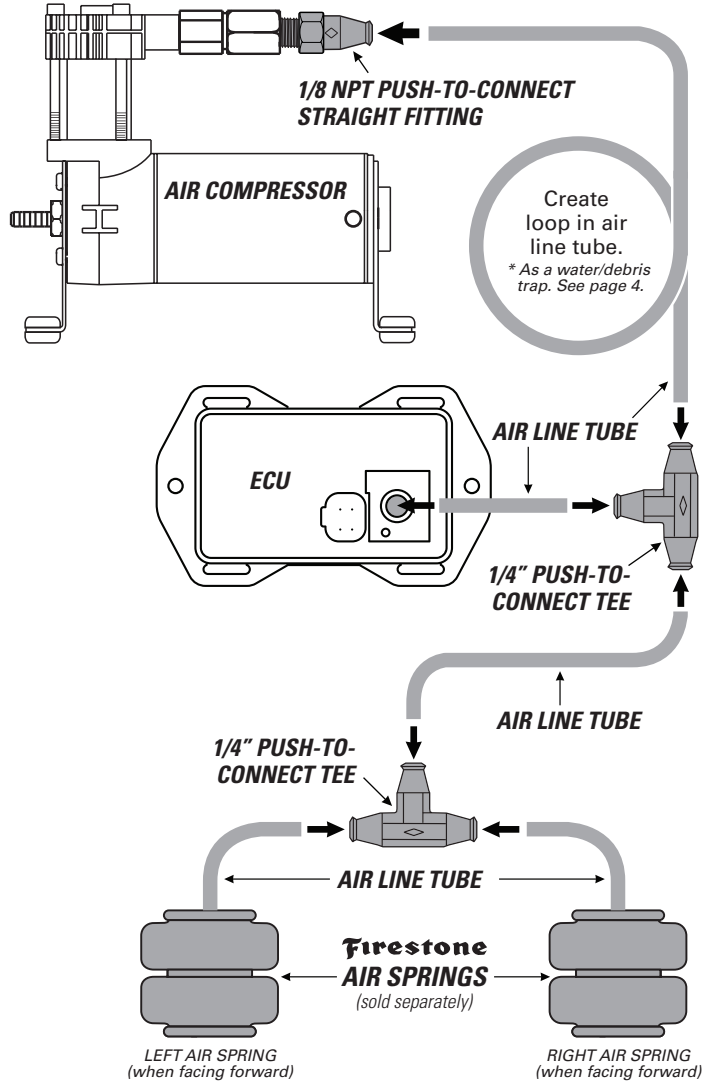

# DO

Make sure the cut is as square as possible. Use a tube cutter or very sharp utility knife.

# DON'T

Fold or kink the air line tube. Cut the air line tube at an angle. Use pliers, scissors, snips, saws, or side cutters.

### PROPER AND IMPROPER CUTS IN THE AIR LINE TUBE

<p>Square cut</p> <p><b>AIR LINE TUBE</b></p> <p>90°</p>	<p><b>AIR LINE TUBE</b></p> <p>X</p>	<p><b>AIR LINE TUBE</b></p> <p>X</p>	<p><b>AIR LINE TUBE</b></p> <p>X</p>
--	--------------------------------------	--------------------------------------	--------------------------------------

## OPTIONAL INFLATION VALVE INSTALL

# 6

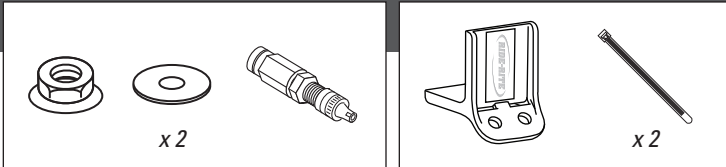

IF USING THE OPTIONAL NO-DRILL INFLATION VALVE BRACKET, CHOOSE OPTION 1. IF DRILLING, CHOOSE OPTION 2. **INFLATION VALVE MUST BE ACCESSIBLE BY AN AIR CHUCK.**

- 1 Secure the air inflation valve bracket to a protected, secure location. PROCEED TO STEP 3.

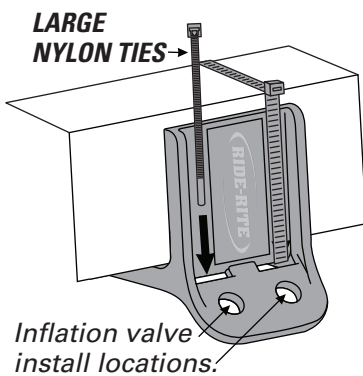

- 2 Select a protected location to install the inflation valve, such as the bumper or the body of the vehicle.

Drill a 5/16" hole for inflation valve install location.

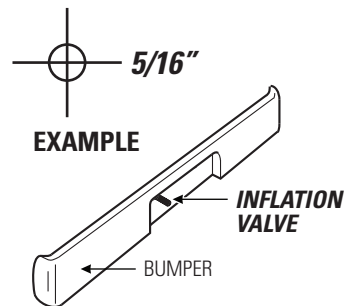

- 3 Install inflation valve assembly as shown.

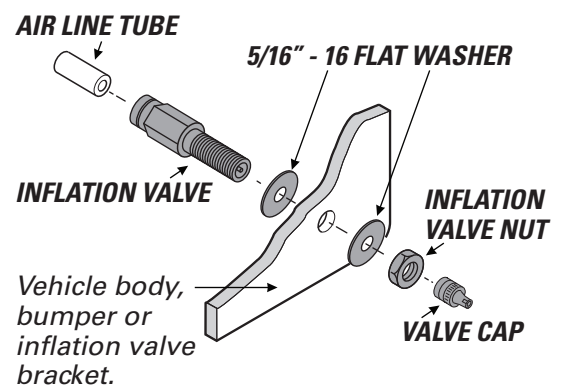

## RUN AIR LINE TO OPTIONAL INFLATION VALVE

# 7

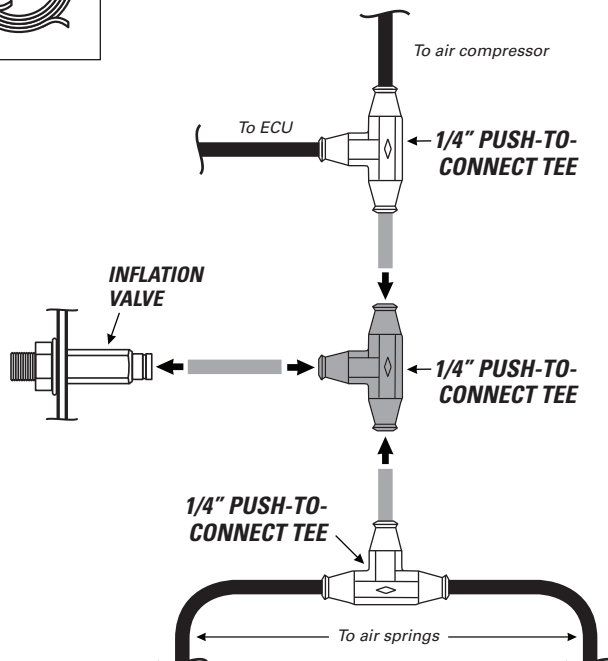
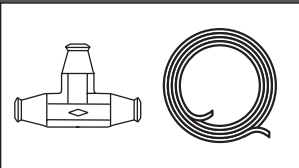

- 1 Run air line tube from the location of the installed inflation valve in step 7 to the air line tube that connects the two installed 1/4" push-to-connect tees.

- 2 Cut the piece of air line tube that connects the two installed 1/4" push-to-connect tees.

- 3 Install the air lines into the 1/4" push-to-connect tee, as shown.

- 4 Install the air line tube into the inflation valve, as shown.

# 8

## INSTALLING THE AIR FILTER

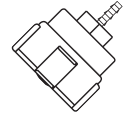

FILTER LIFE WILL VARY BASED ON ENVIRONMENTAL CONDITIONS. PROTECT THE AIR COMPRESSOR BY CHANGING THE AIR FILTER MORE FREQUENTLY IN DUSTY CONDITIONS.

**1** Fully secure the air filter barb into the air line tube from the air compressor kit.

**2** Press air line tube onto the barb on the air compressor air fitting until fully seated. Assure you create a loop in the air line tube, as shown, when securing it to the vehicle.

**3** Periodically check the air filter during operation. When the air filter is dirty and needs to be replaced, contact an Authorized Firestone dealer to purchase a new one.



SECURE THE AIR FILTER IN A LOCATION THAT PROTECTS IT FROM MOISTURE AND DEBRIS, AND IS ABOVE THE LOOP IN THE AIR LINE TUBE.

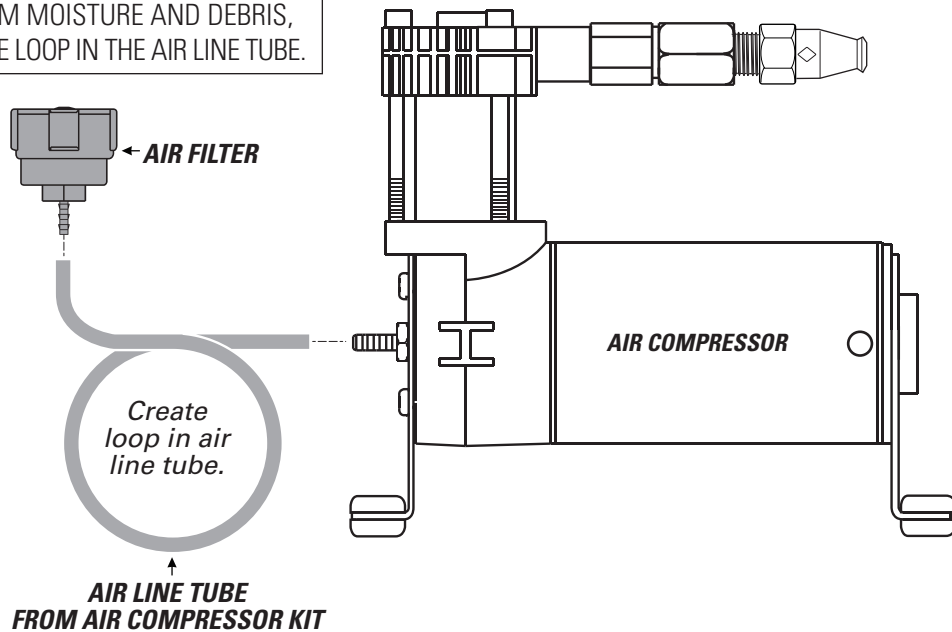

# 9

## CLEAN UP INSTALLATION



**1** Clean up the installation using supplied Nylon ties, and return all factory parts and materials to operative state.



USING SUPPLIED NYLON TIES, SECURE ALL WIRING AND AIR LINE TUBE IN A MANNER THAT DOES NOT OBSTRUCT MOVING PARTS OR IN ANY WAY THAT AFFECTS YOUR ABILITY TO SAFELY OPERATE THE VEHICLE.

**1** Download and install the Firestone Air Command app on a compatible iPhone or Android device.

**2** Open the app. Once the app has established a Bluetooth connection on startup, it will automatically link to the ECU.

**MAIN APP SCREEN**

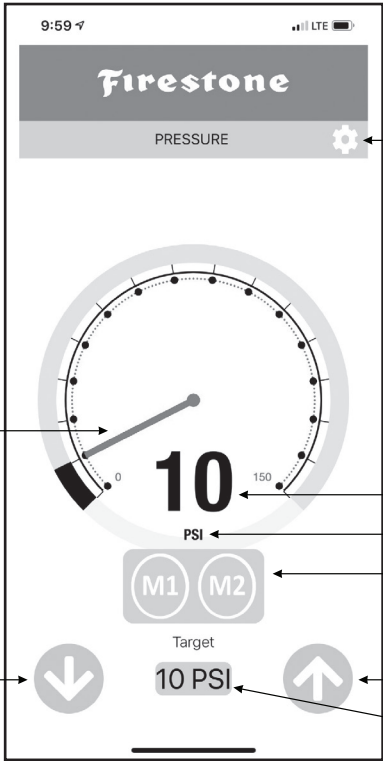

**NEEDLE AND BAR**  
Shows actual pressure. Can be used to change pressure.

**SETTINGS**

**ACTUAL PRESSURE**

**UNITS**

**MEMORY BUTTONS**  
To set memory, hold down target pressure, then press M1 or M2.

**DECREASE PRESSURE**

**INCREASE PRESSURE**

**TARGET PRESSURE**  
Set by user.

**SETTINGS**

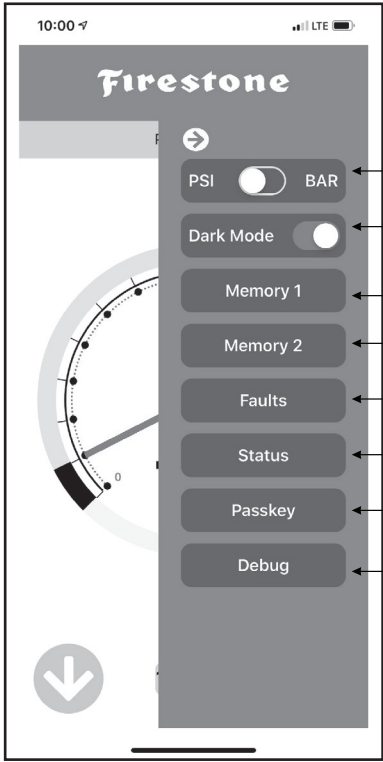

**CHANGE UNITS**

**CHANGE DARK MODE**  
Auto adjust to ambient light for contrast.

**SET AND NAME MEMORY 1**

**SET AND NAME MEMORY 2**

**SHOW FAULTS SCREEN**

**SHOW SYSTEM STATUS SCREEN**

**CHANGE PASSKEY**  
User set or default (123456).

**SHOW LOG SCREEN FOR TROUBLESHOOTING**

\* Any faults will include troubleshooting instructions

# 11

## TEST THE SYSTEM

With the Air Command™ F3 kit and your air springs installed, you are ready to test the system.

- 1 Reattach the negative battery cable.

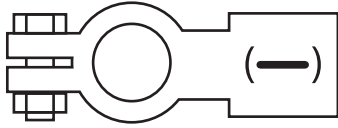

- 2 Turn on your vehicle's ignition.

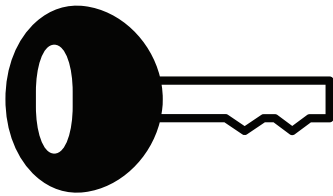

- 3 Use the app to inflate the air springs to 70 PSI. See step 10 for details.

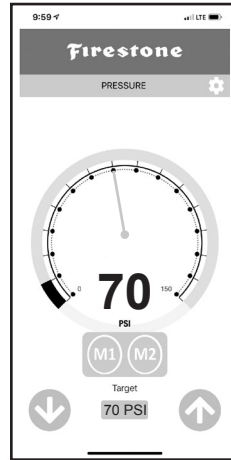

- 4 Spray fittings with soap and water mixture or glass cleaner.



- 5 Observe bubbles.

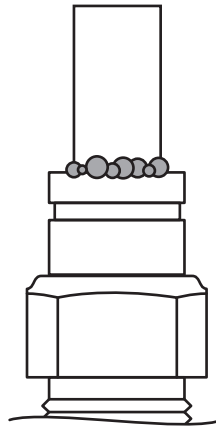

**SMALL SOAP BUBBLES  
THAT DO NOT EXPAND**

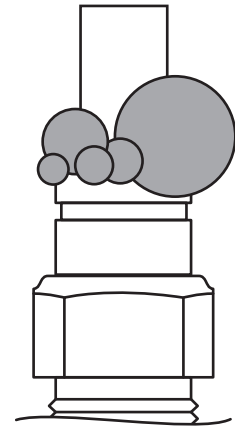

**SOAP BUBBLES  
THAT EXPAND**



# NO LEAKS?

Congratulations! You're riding right with the push of a button! Remember to review the Operating Instructions.

# LEAK?

Bummer. Continue to step 12 to fix the leak.



EXHAUST ALL AIR FROM THE SYSTEM PRIOR TO RELEASING AIR TUBES FROM AIR FITTINGS.



- 1 Use the app to deflate the air springs to 5 PSI. See step 10 for details.

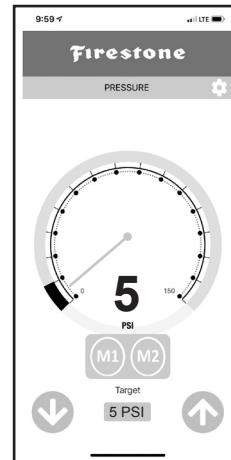

#### LEAK AT AIR LINE TUBE AND AIR FITTING

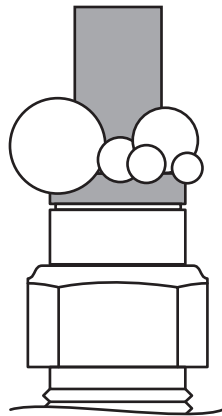

Release air line tube (see page 4). Review proper cuts and procedures in step 5. Repeat step 5.

#### LEAK AT BASE OF AIR FITTING

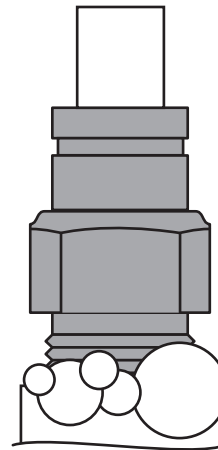

Tighten Air Fitting one turn or until leak stops.

## STILL HAVE A LEAK?

Refer to the Troubleshooting section of the Instruction Manual. If the leak persists, or if there is an issue with a leaking part, call 1-800-888-0650; Option 1; Option 1 for Tech Support.





[riderite.com](http://riderite.com)

## BEFORE YOU DRIVE, CONFIRM THE FOLLOWING:

- Secure all air line tubes and wiring.
- The system passes the leak test and holds air.
- The air compressor ground ring terminal is contacting bare metal, and coated with silicone if possible.
- The wire harness is grounded to the negative (-) battery terminal. The ECU needs a good, clean, interference-free ground.
- There is a loop in the air line tubes as shown to prevent water or debris from getting into the air compressor head and damaging it.

## NEED INSTALLATION HELP? 1-800-888-0650

Select option 1 for Ride-Rite; Select option 1 for Technical Support.

Or, email us at [rrtech@fsip.com](mailto:rrtech@fsip.com). Please include photos to help us better diagnose and understand any problems you may be experiencing.

# Firestone

Firestone Industrial Products

CONNECT WITH US



FirestoneIP



Firestone Ride-Rite