

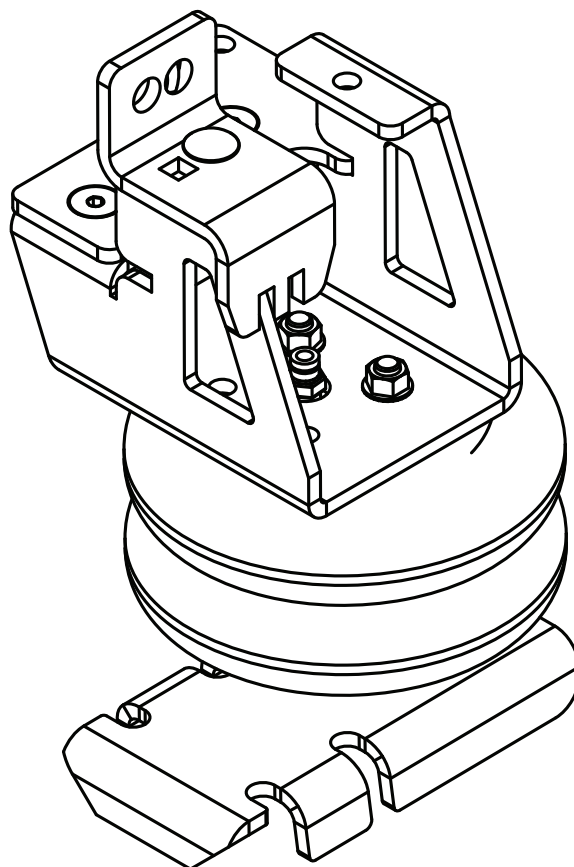

riderite.com

INSTALLATION INSTRUCTIONS



Firestone

Firestone Industrial Products

! IMPORTANT

PLEASE DON'T HURT YOURSELF, YOUR KIT OR YOUR VEHICLE. TAKE A MINUTE TO READ THIS IMPORTANT INFORMATION.

DO NOT INSTALL IF THE TRUCK HAS BEEN LIFTED AND THE STOCK JOUNCE BUMPER SPACERS ARE NOT ON THE VEHICLE. *This kit is to be used on a pickup truck only, and DOES NOT INCREASE YOUR VEHICLE'S MAXIMUM LOAD.*

SAFE INSTALLATION

Please take all safety precautions during installation. A hydraulic jack can fail, and if that happens, you can be seriously hurt, or worse, if you are relying on it to hold up the vehicle. If you use a hydraulic jack, secure jack stands in the appropriate locations and chock any tires still touching the ground.

Wear safety glasses or goggles. Your eyes may be lower than some parts and pieces, and you don't want to lose an eye.

Remove the possibility of any electrical issues by disconnecting the negative battery cable.

KIT CLEARANCE

There must be a minimum of 1/2" clearance around all installed components when the air springs are inflated and under a load. The air springs must flex and expand during operation, so the clearance keeps the kit from rubbing against parts of the vehicle.

VEHICLE GVWR

NEVER exceed the maximum load recommended by the vehicle manufacturer (GVWR). The GVWR can be found in your vehicle's owner's manual or on the data plate on the driver's side door.

INFLATING THE AIR SPRINGS

When inflating air springs, add air pressure in small quantities, checking air pressure frequently. The air springs have much less air volume than a tire, so they inflate much more quickly.

PRESSURE TO LOAD

The air springs will support approximately 50 lbs. of load for each PSI of inflation pressure (per pair). For example, 50 PSI of inflation pressure will support a load of 2500 lbs. per pair of air springs.

APPROPRIATE AIR PRESSURE

For best ride, use only enough air pressure in the air springs to level the vehicle when viewed from the side (front to rear). This will vary, depending on the load, location of the load, condition of the existing suspension, and personal preference.

OPTIONAL T-FITTING



This kit includes inflation valves and air line tube for each air spring, allowing you to compensate for unbalanced loads. If you prefer a single inflation valve system to provide equal pressure to both air springs, your dealer can supply the optional "T" fitting (Part # 3025 or WRI-760-3461 retail pack).

ONCE INSTALLED SUCCESSFULLY, FOLLOW THESE PRESSURE REQUIREMENTS FOR THE AIR SPRINGS:



MINIMUM PRESSURE









MAXIMUM PRESSURE (LOADED)

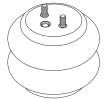
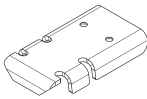

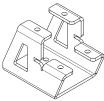
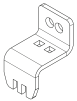
PARTS

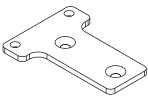
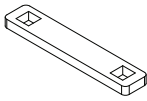
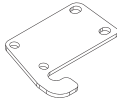
Compare the parts below to your kit. Assure you have all pieces, and organize them for an easier installation.









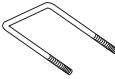

MAIN KIT CONTENTS

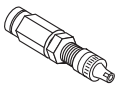
PT # 6781	 x2 AIR SPRING	PT # 5934	 x2 LOWER BRACKET	PT # 1004	 x1 HEAT SHIELD
PT # 5930	 x2 UPPER BRACKET	PT # 5932	 x2 FRAME BRACKET	PT # 9414	 x1 AIR LINE TUBE (18 FEET)
PT # 5933	 x2 UPPER BRACKET PLATE	PT # 5931	 x2 FRAME BRACKET STRAP	PT # 5893	 x2 SPRING CLAMP PLATE
PT # 5894	 x2 SPACER				

A24-760-7560 INFLATION VALVE BRACKET KIT

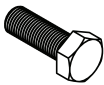
PART # 9483	 x1 NO-DRILL INFLATION VALVE BRACKET	PART # 9488	 x2 LARGE NYLON TIE
-------------	--	-------------	---

A21-760-2594 HARDWARE PACK

PT # 3022	 x22 3/8" - 16 FLANGE LOCK NUT	PT # 3134	 x4 3/8" - 16, 3.62" x 4" x 3" BAIL CLAMP	PT # 9036	 x6 RED NYLON TIE
PT # 3033	 x4 5/16" FLAT WASHER	PT # 3032	 x2 INFLATION VALVE AND VALVE CAP ASSEMBLY	PT # 0899	 x2 THERMAL SLEEVE
PT # 3398	 x4 3/8" - 16 x 1.5" FLAT HEAD BOLT	PT # 3046	 x2 1/4" STRAIGHT AIR FITTING	PT # 3470	 x2 M14 FLAT WASHER
PT # 3512	 x2 M14 x 1.5mm x 40mm CAP SCREW	PT # 3370	 x2 3/8" - 16 x 3/4" FLAT HEAD BOLT		
PT # 3502	 x4 3/8 - 16 x 6 CARRIAGE BOLT	PT # 3072	 x2 3/8 - 16 x 1 CARRIAGE BOLT		

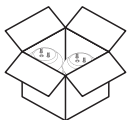
IF YOU DON'T HAVE ALL THE PARTS OR RECEIVED A BOX THAT WASN'T IN NEW / UNOPENED CONDITION – CONTACT THE SELLER YOU PURCHASED IT FROM.

CONTENTS AND OVERVIEW

PAGE **4** BUILD UPPER BRACKET ASSEMBLY

PAGE **5** ASSEMBLE AIR SPRING TO UPPER BRACKET ASSEMBLY

PAGE **5** ASSEMBLE LOWER BRACKET TO AIR SPRING

PAGE **6** INSTALL AIR SPRING ASSEMBLY TO FRAME

PAGE **7** POSITION LOWER BRACKET AND TIGHTEN FASTENER

PAGE **8** FASTEN LOWER BRACKET TO LEAF SPRINGS

PAGE **9** INSTALL HEAT SHIELD

PAGE **10** AIR LINE TUBE & INFLATION VALVE INSTALLATION

PAGE **11** INSTALL & ROUTE AIR LINE TUBE

PAGE **12** CHECKING THE SYSTEM

PAGE **13** FIXING AN AIR LEAK

PAGE **14** FINISHING THE INSTALLATION

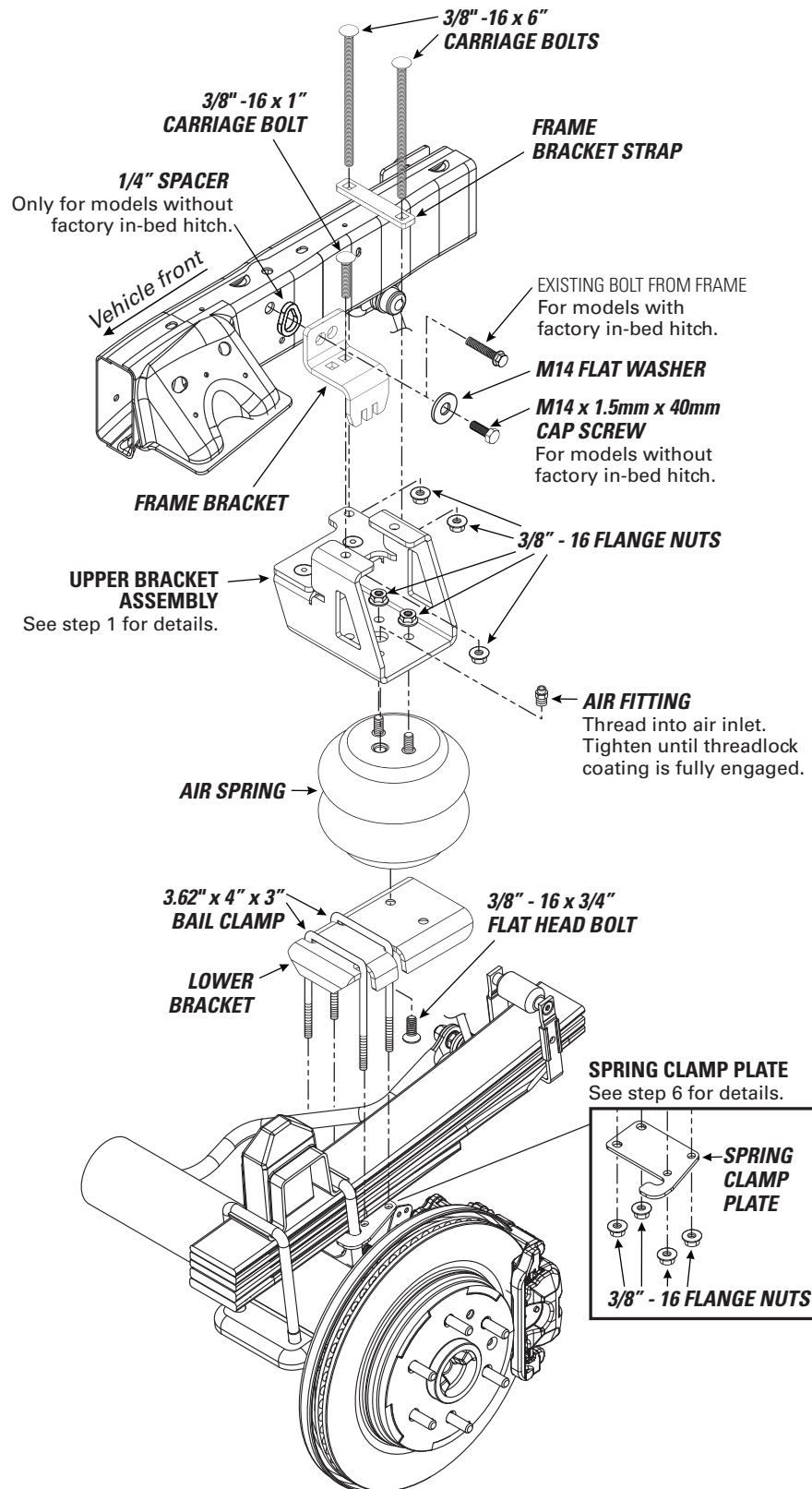

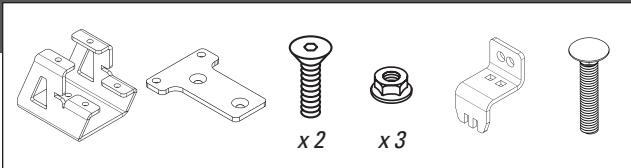

1 Connect brackets using flat head bolts and flange nuts, as shown.



START THE INSTALLATION ON THE LEFT SIDE OF THE VEHICLE WHEN FACING FORWARD.

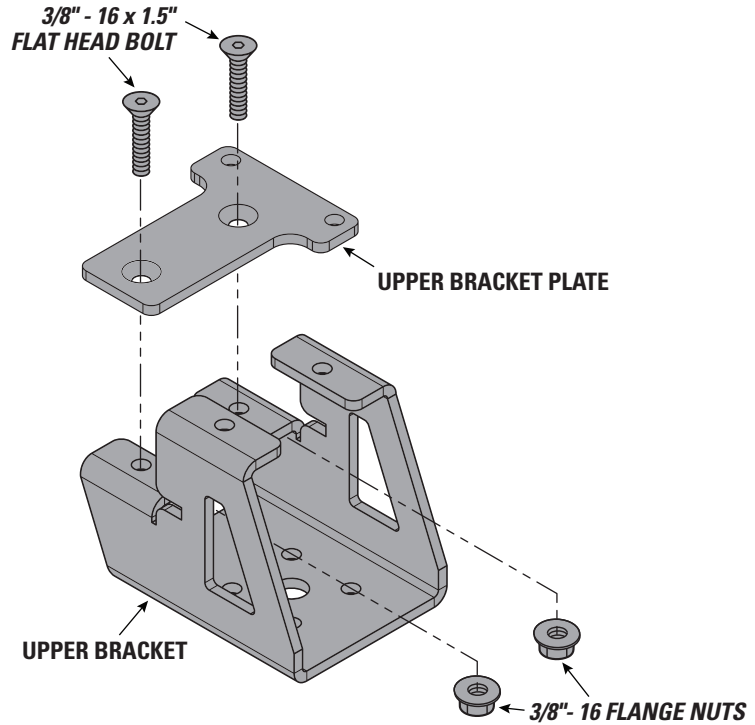

2 Fasten frame bracket to upper bracket using bolt hole and bracket slot shown.

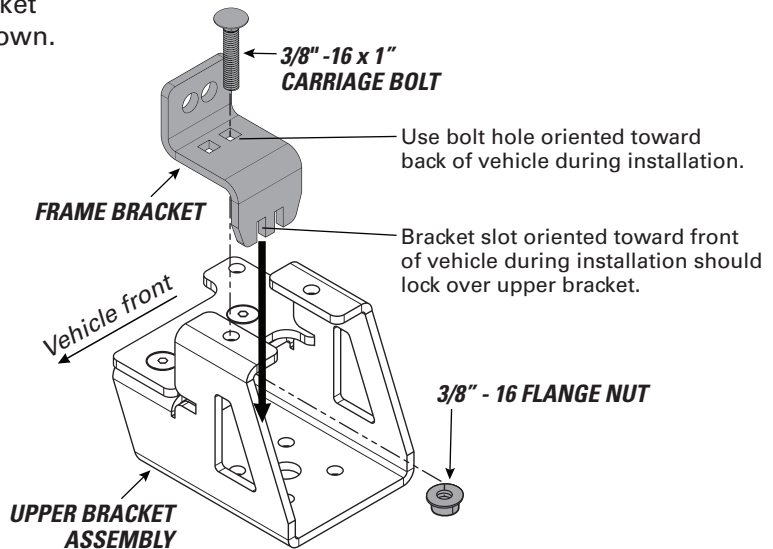

2

ASSEMBLE AIR SPRING TO UPPER BRACKET ASSEMBLY



INSTALLING THE RIGHT SIDE? REMEMBER TO GO TO STEP 7 FIRST TO INSTALL THE HEAT SHIELD.

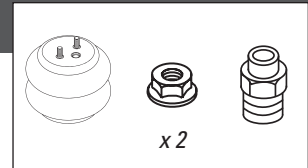

1 Install air fitting onto air spring, as shown.

2 Using the two bracket holes toward the back of the vehicle, install the air spring to the bracket assembly, as shown.

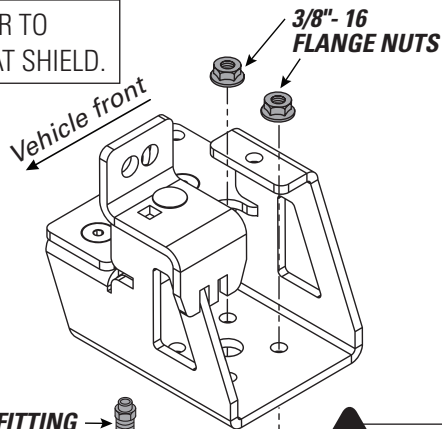

AIR FITTING
Thread into air inlet.
Tighten until threadlock coating is fully engaged.



USE THE BRACKET HOLES TOWARD THE BACK OF THE VEHICLE.

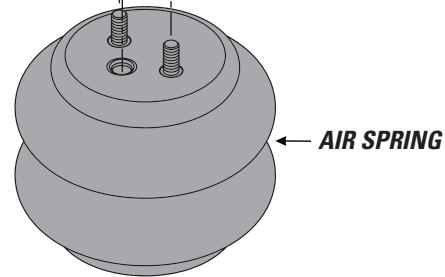

3

ASSEMBLE LOWER BRACKET TO AIR SPRING

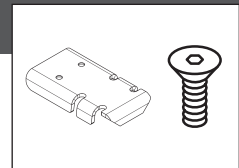

1 Using the inboard hole on the lower bracket, fasten it to the air spring, as shown. **DO NOT FULLY TIGHTEN THE FASTENER AT THIS STAGE.**

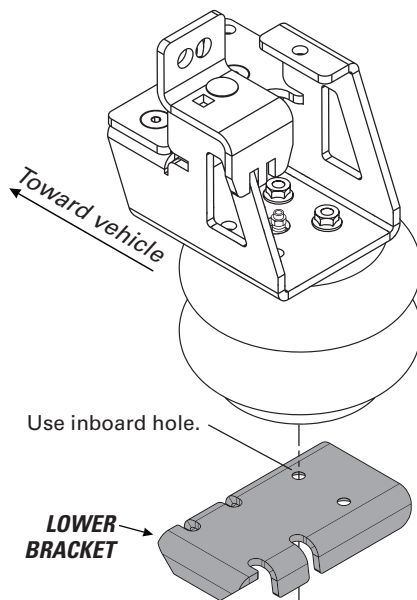

Use inboard hole.



USE THE INBOARD HOLE ON THE LOWER BRACKET.



DO NOT FULLY TIGHTEN THE FASTENER AT THIS STAGE.

3/8\"/>

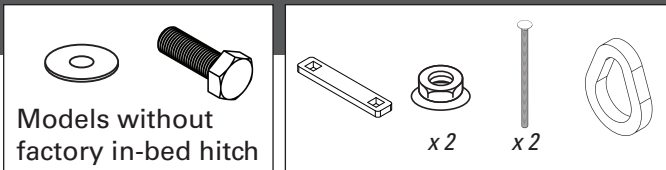

1 Remove the existing bolt from the frame, as shown.

2 For models with a factory in-bed hitch, fasten the frame bracket to the frame using the existing bolt and the spacer. Models without a factory in-bed hitch should use the supplied fasteners, as shown.

3 Install the frame bracket strap over the frame and secure to the air spring assembly. **Tighten the frame bracket to the frame first, then the 3/8" - 16 flange nuts to the carriage bolts.**

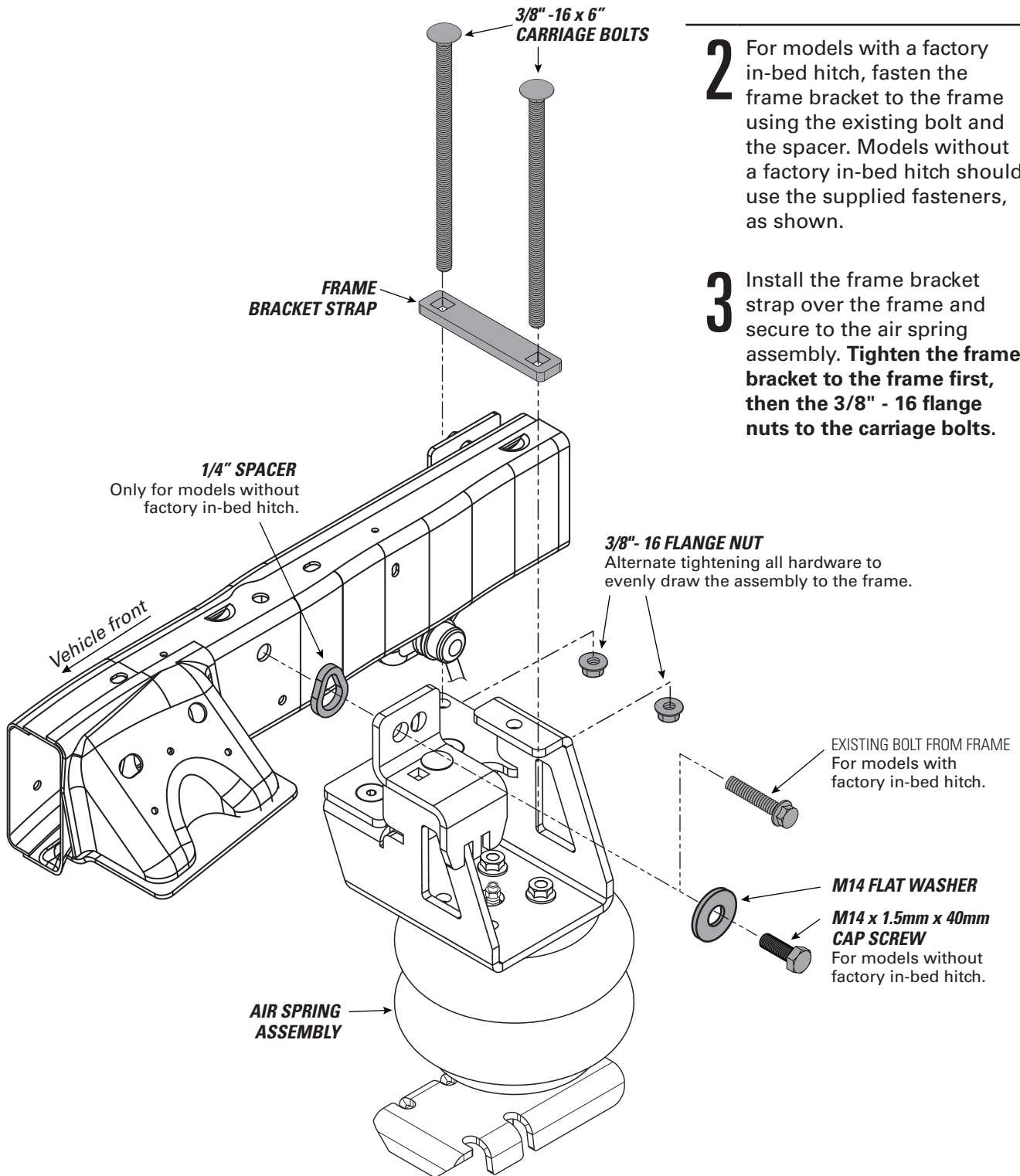

5

POSITION LOWER BRACKET AND TIGHTEN FASTENER

1 Slide lower bracket forward until flange hooks over U-bolt.

2 Make alignment marks, as shown. Using alignment marks ensures that the air spring isn't twisted during final assembly.

3 Match alignment marks you made, then **fully tighten the 3/8" - 16 x 3/4" flat head bolt on the bottom of the lower bracket.**

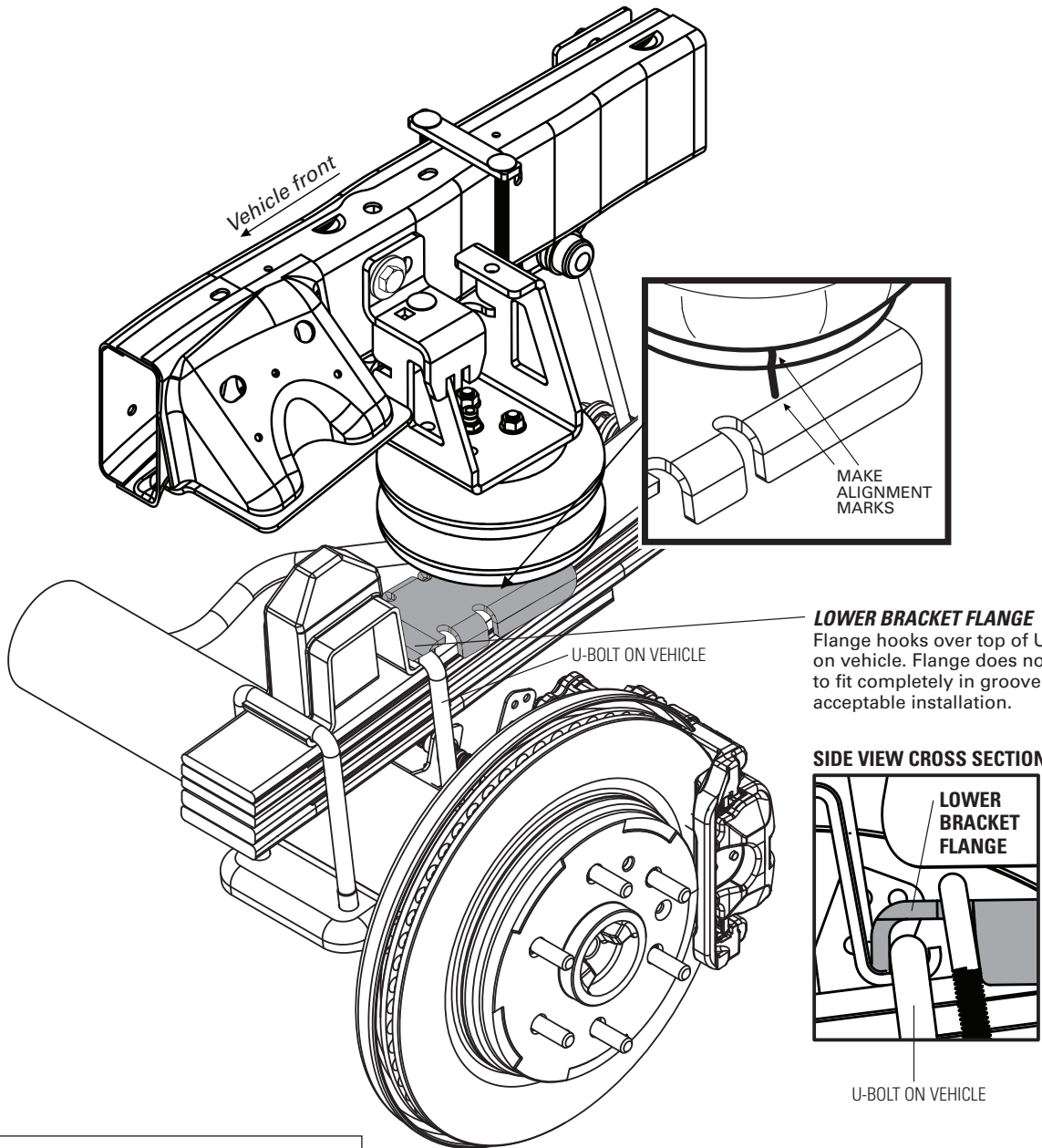

REMEMBER TO FULLY TIGHTEN THE FLAT HEAD BOLT TO THE BOTTOM OF THE AIR SPRING.

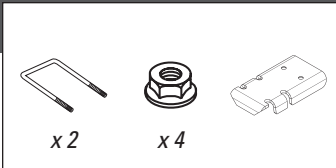

1 Install the bail clamps over the slots on the lower bracket.

2 Slide the spring clamp plate into position, assuring that the tab hooks around the U-bolt leg on the vehicle.

3 Tighten the flange nuts onto the bail clamp threads. **DO NOT OVER-TIGHTEN BOLTS! SEE BELOW.**

RIGHT SIDE VIEW FROM FRONT

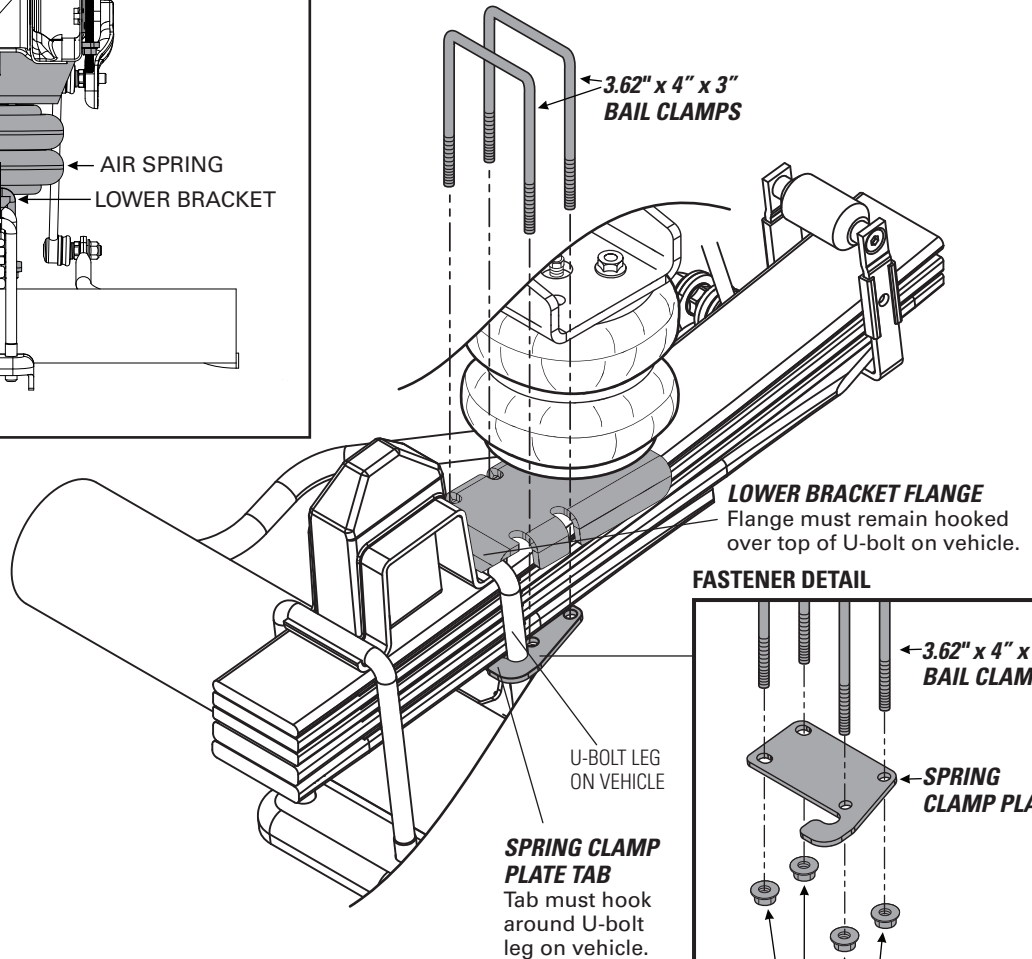
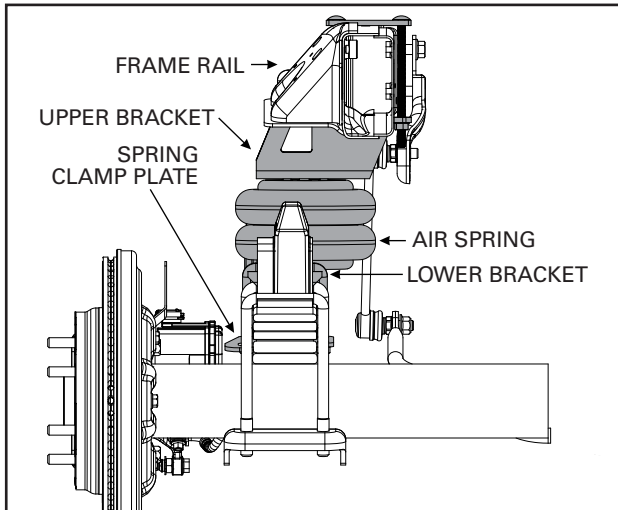

LOWER BRACKET FLANGE
Flange must remain hooked over top of U-bolt on vehicle.

FASTENER DETAIL

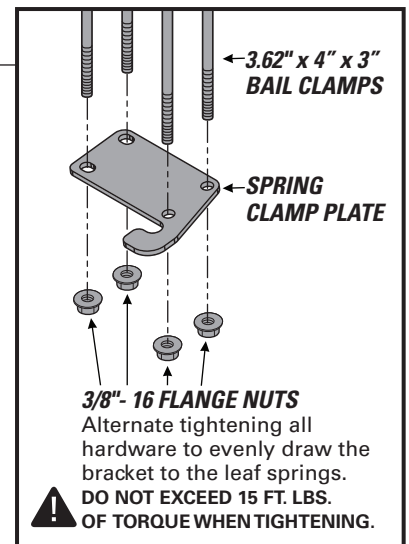

3/8\"- 16 FLANGE NUTS
Alternate tightening all hardware to evenly draw the bracket to the leaf springs. **DO NOT EXCEED 15 FT. LBS. OF TORQUE WHEN TIGHTENING.**



USE YOUR HAND TO CHECK FOR THE PROPER CLEARANCE AROUND THE AIR SPRING, ESPECIALLY BETWEEN THE AIR SPRING AND THE TIRE/WHEEL. IF YOUR HAND DOES NOT FIT BETWEEN THE AIR SPRING AND OTHER COMPONENTS, IT WILL RUB!



AWESOME! You're done with the left side. Go back to step 1 and repeat the steps for the right side installation, including step 7 for the heat shield.

7

INSTALL HEAT SHIELD

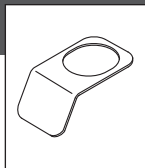

RIGHT SIDE INSTALLATION MUST INCLUDE HEAT SHIELD!

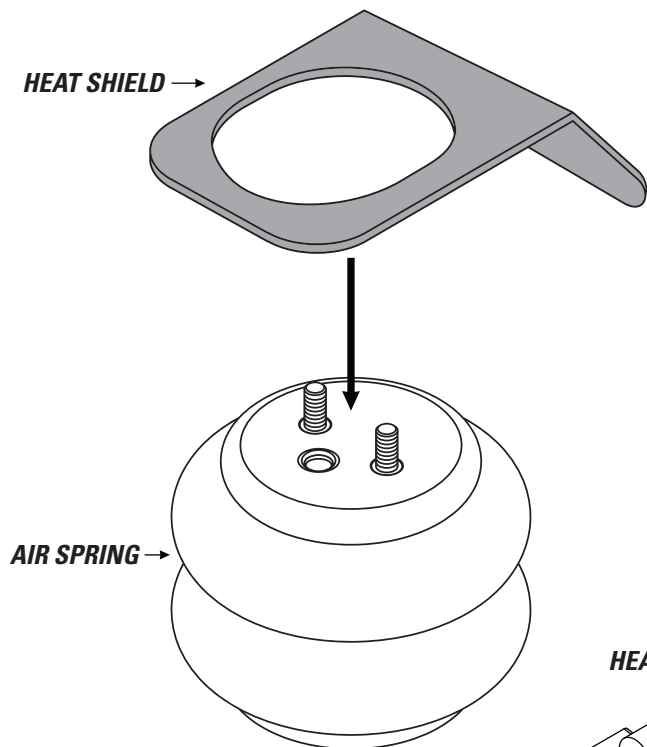

1 Secure heat shield by clamping between air spring and upper bracket.

Position Heat Shield to closest point of exhaust. DO NOT PLACE DIRECTLY ABOVE AXLE.

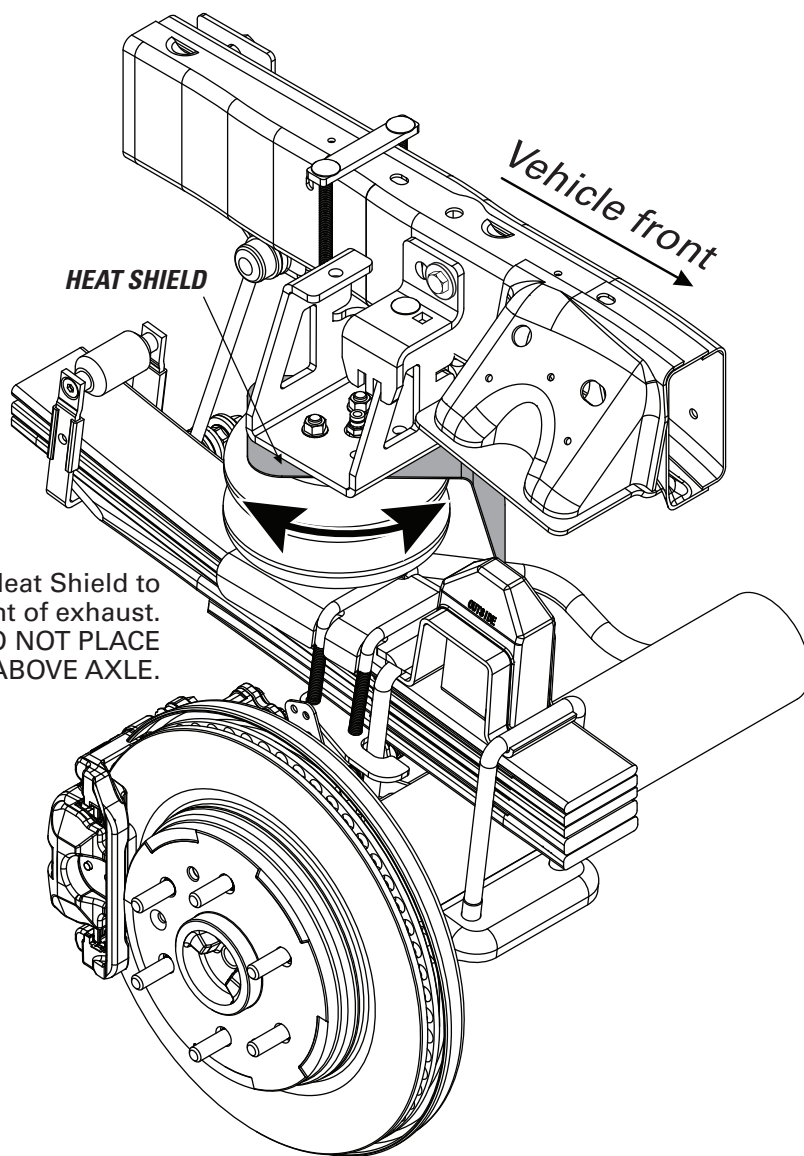

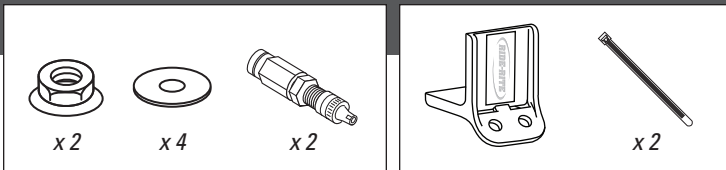

IF USING THE OPTIONAL NO-DRILL INFLATION VALVE BRACKET, CHOOSE OPTION 1. IF DRILLING, CHOOSE OPTION 2. **INFLATION VALVES MUST BE ACCESSIBLE BY AN AIR CHUCK.**

1 Secure the air inflation valve bracket to a protected, secure location. **PROCEED TO STEP 3.**

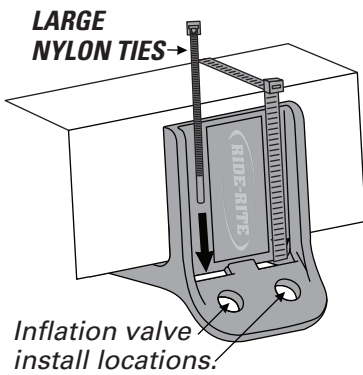

2 Select a protected location to install the inflation valves, such as the bumper or the body of the vehicle.

Drill two 5/16" holes for Inflation Valve install locations.

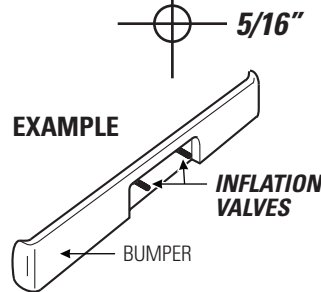

3 Install inflation valve assembly as shown.

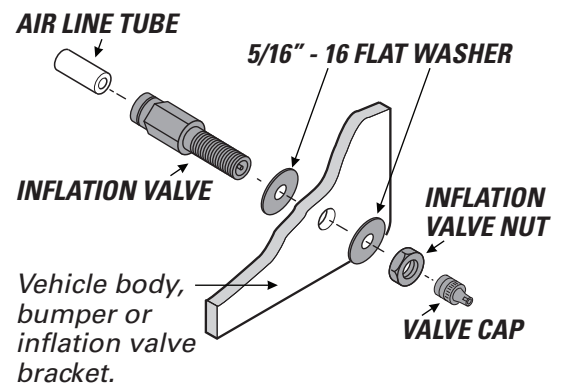

1 Match air line tube ends.



2 Find center of air line tube, make a square cut with tube cutter or sharp utility knife.

DO

Make sure the cut is as square as possible. Use a tube cutter or sharp utility knife.

DON'T

Fold or kink the air line tube. Cut the air line tube at an angle. Use pliers, scissors, snips, saws, or side cutters.

PROPER AND IMPROPER CUTS IN THE AIR LINE TUBE

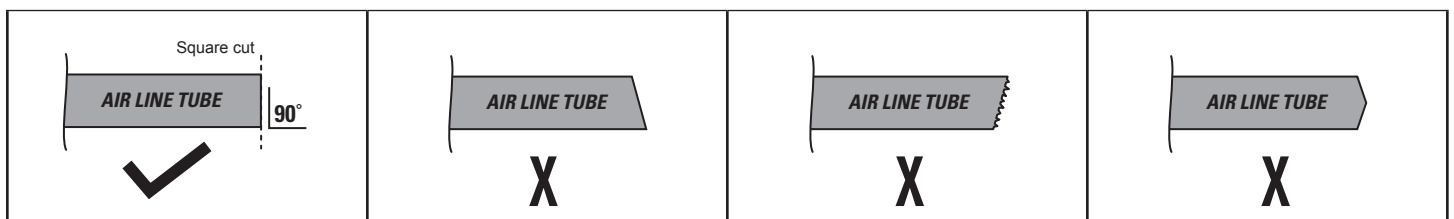

10

INSTALLING AIR LINE TUBE INTO AIR FITTINGS AND INFLATION VALVE

1 Insert end of air line tube into air fitting.

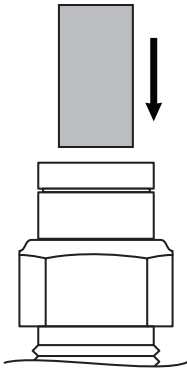

2 Push air line tube into air fitting as far as possible.

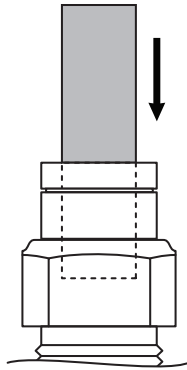

3 Gently pull on the air line tube to check for a secure fit.

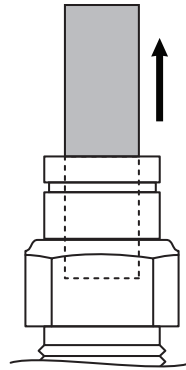

4 To remove, push down collar and gently pull air line tube away.

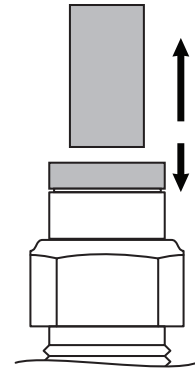

Removal Tip: Use a 1/4", 5/16", or 6mm open-ended wrench to push the collar down.

11

ROUTE AND SECURE AIR LINE TUBES

Air line tube routes will vary, depending on your truck, and requires you to choose the best path from the air springs to the inflation valves. Use the instructions below to help you choose.

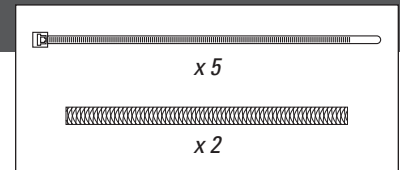

DO

Select routes protected from heat, debris, and sharp edges. Use thermal shields near heat sources. Use Nylon ties to secure the air line tube.

DON'T

Bend or sharply curve air line tubes. Leave air line tube exposed to sharp edges. Use unnecessary lengths of air line tube. Route air line tube near moving parts. Let air line tube hang unsecured from vehicle. Scar air line tube while routing.

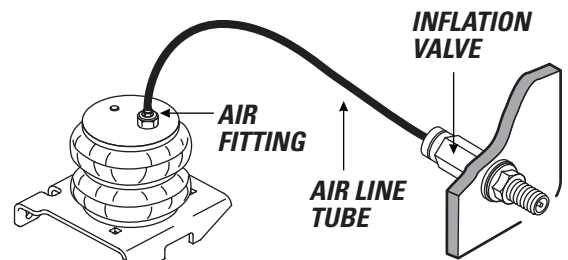
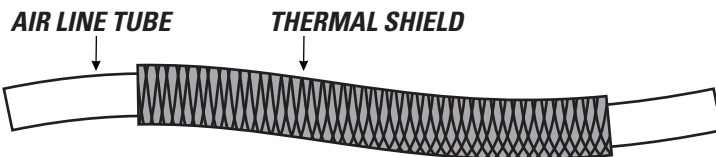

USE SUPPLIED THERMAL SHIELDS WHEN AIR LINE TUBE RUNS **WITHIN 6 INCHES** OF HEAT SOURCES.



- 1** Place an air chuck onto the inflation valve and fill the system to **70 PSI**.

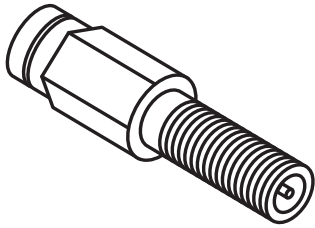

AIR SPRINGS INFLATE QUICKLY. CHECK AIR PRESSURE WHILE INFLATING.

- 2** Spray fittings with soap and water mixture.



- 3** Observe bubbles.

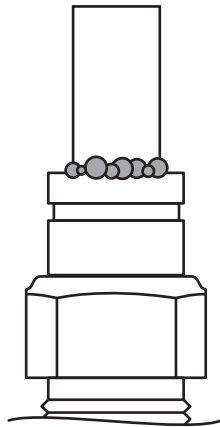

**SMALL SOAP BUBBLES
THAT DO NOT EXPAND**

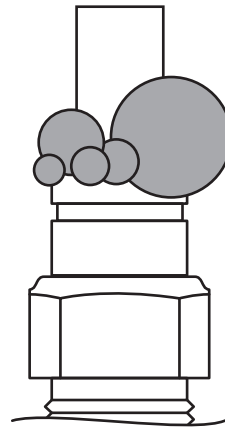

**SOAP BUBBLES
THAT EXPAND**



NO LEAKS?

Congratulations! Continue to step 14 to finish installation. Review the Operating Instructions.

LEAK?

Bummer. Continue to step 13 to fix the leak.

- 1** Press the air valve on end of inflation valve to release all air pressure.

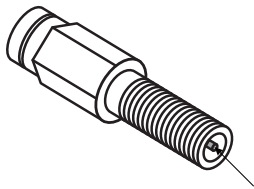

AIR VALVE



EXHAUST ALL AIR FROM THE SYSTEM PRIOR TO RELEASING AIR LINE TUBES FROM AIR FITTINGS.

LEAK AT AIR LINE TUBE AND AIR FITTING

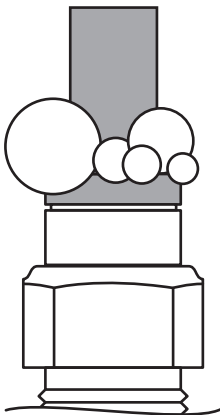

Release air line tube (see page 11). Review proper cuts and procedures in step 9. Repeat steps 10 and 12.

LEAK AT BASE OF AIR FITTING ON AIR SPRING

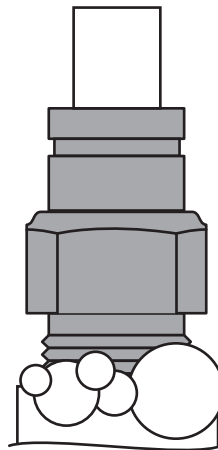

Tighten air fitting one turn or until leak stops.

LEAK OUT OF THE VALVE CORE ON INFLATION VALVE

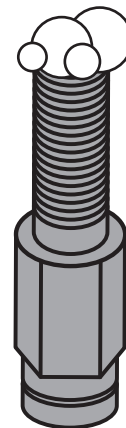

Tighten valve core with valve core wrench on inflation valve cap.

STILL HAVE A LEAK?

Refer to the Troubleshooting section of the Instruction Manual.

SAFELY RETURN VEHICLE TO OPERATIVE STATE

If you removed any wheels during installation, install the wheels and torque the lug nuts to the manufacturer's specifications.

Safely remove any jack stands and wheel chocks used during installation.

Re-attach the negative battery cable.

DOUBLE-CHECK AIR SPRING CLEARANCE

Check the air springs once again for the proper 1/2" minimum clearance. Perform clearance check again when vehicle is under load.

VEHICLE GVWR

NEVER exceed the maximum load recommended by the vehicle manufacturer (GVWR). The GVWR can be found in your vehicle's owner's manual or on the data plate on the driver's side door. Consult your local dealership for additional GVWR specifications.

READ AND UNDERSTAND THE OPERATING INSTRUCTIONS

The Ride-Rite system can improve handling and comfort. Take the time to learn how to properly use and maintain your investment by reading the Operating Instructions.



USE YOUR HAND TO CHECK FOR THE PROPER CLEARANCE AROUND THE AIR SPRING. IF YOUR HAND DOES NOT FIT BETWEEN THE AIR SPRING AND OTHER COMPONENTS, IT WILL RUB!

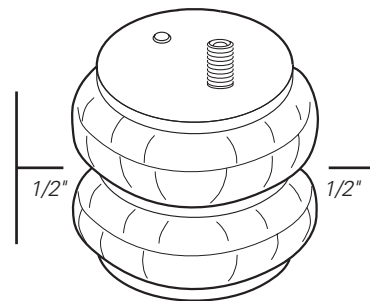

! IMPORTANT

A MINIMUM OF 5 PSI MUST BE MAINTAINED IN THE AIR SPRINGS AT ALL TIMES

Too much air pressure in the air springs will result in a firmer ride, while too little air pressure will allow the air springs to bottom out over rough conditions, and will not provide the improvement in handling that is possible.



MINIMUM PRESSURE



MAXIMUM PRESSURE (LOADED)



riderite.com

BEFORE YOU DRIVE, CONFIRM THE FOLLOWING:

- Do you have a minimum of 5PSI in your air springs?
- Are your air springs standing 7" - 8" tall? **7" - 8"**
- Are your air springs properly aligned, left-to-right and front-to-back?
- Are your nuts and bolts tight?
- Put your paper work back into the sleeve and keep it in your glove compartment for future reference.
- You've been bagged...and now your suspension is Airide™ equipped! Show it off with the supplied decal!

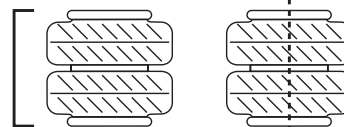

NEED INSTALLATION HELP?

Email us at rrtech@fsip.com. Please include photos to help us better diagnose and understand any problems you may be experiencing.

Firestone
Firestone Industrial Products

CONNECT WITH US



FirestoneIP



Firestone Ride-Rite